

General Electric Company

Long-Term Remediation Plan for the Altitude Test Facility (ATF)

GE Aviation, Cincinnati, Ohio

December 2013



**Long-Term Remediation Plan
for the Altitude Test Facility
(ATF)**

GE Aviation
Cincinnati, Ohio

Prepared for:
General Electric Company

Prepared by:
ARCADIS U.S., Inc.
6723 Towpath Road
P O Box 66
Syracuse
New York 13214-0066
Tel 315 446 9120
Fax 315 449 0017

Our Ref.:
B0031231

Date:
December 2013

1. Introduction	1
2. Background & Overview	4
2.1 ATF Operations	4
2.2 Interim Plan for Current Testing Operations	4
3. Paint Removal Efforts	6
3.1 Introduction	6
3.2 Paint Removal from the Interior of Pipe	6
3.3 Paint Removal from the Exterior of Pipe/Appurtenances	7
4. Pipe with ACM Insulation and Barrier	8
4.1 Introduction	8
4.2 Description of the Insulating Barrier	8
4.3 Pipe Replacement Plans (Including ACM Management Procedures)	9
4.4 Operation and Maintenance Plan For Pipe Encapsulated By The Insulating Barrier	11
4.4.1 Introduction	11
4.4.2 Piping Network Inspections	14
4.4.3 Pipe / Barrier Repair and Replacement	15
5. Waste Management	17
6. Work Schedule	18
7. PCB Awareness	19
8. Maintenance Record Keeping	20
9. Reporting	21
9.1 Final Completion Report	21
9.2 Annual Report / Condition Assessment Report	21

Attachments

- A GE Aviation Short-Term Section 761.62(c) Submission (November 16, 2012)
- B USEPA Region 5 December 19, 2012 Conditional Approval Letter
- C Indoor Ambient Air PCB Monitoring Plan
- D Asbestos-Containing Material (ACM) Paint Sampling and Analyses
- E Multi-Layered Barrier Photos
- F O&M Plan

1. Introduction

This Long-Term Remediation Plan (Plan), developed by ARCADIS, U.S., Inc. (ARCADIS) on behalf of the General Electric Company (GE), describes the long-term solution to address the presence of paint containing ≥ 50 parts per million (ppm) polychlorinated biphenyls (PCBs) that was discovered on the air induction system at the Altitude Test Facility (ATF) at GE's jet engine manufacturing facility in Cincinnati, Ohio. This Plan abates the risk of potential exposure to PCB-containing paint while also controlling risks associated with potential exposure to asbestos and challenging occupational safety conditions (e.g., working at heights, confined spaces). Ultimately, when managed in accordance with this Plan, the paint in the ATF that contains > 50 ppm PCBs will not pose an unreasonable risk of injury to health or the environment.

The ATF tests jet engines for military and commercial customers. The purpose of the ATF is to test jet engines in conditions that simulate the use of engines at a wide range of altitudes (up to 30,000 feet) and speeds (over 2,000 mph). The ATF is one of only two facilities that exist in the US that has these capabilities (the other is owned and operated by the US Air Force).

On November 16, 2012, the "GE Aviation Short-Term Section 761.62(c) Submission" was submitted to the United States Environmental Protection Agency (USEPA) Region 5 ("GE 2012 Submission;" provided herein as **Attachment A**). In the 2012 Submission, GE proposed to use the ATF for jet engine testing until July 31, 2013, based on the implementation of an interim risk-based alternative solution. On December 19, 2012, USEPA approved the use of the ATF, subject to the interim proposal by GE and certain other conditions ("2012 Approval"; provided as **Attachment B**). Pursuant to Condition 13 of the 2012 Approval, GE submitted an Air Monitoring Plan for interim engine testing operations on January 8, 2013 (provided as **Attachment C**).

The submission of this Plan is in accordance with Condition 17 of the 2012 Approval. The central elements of this Plan are:

- Remove and replace up to 300 feet of air induction system piping.
- Remove paint containing ≥ 50 ppm PCBs located on the interior of the remaining portions of the ATF's air induction system piping (approximately 1,500 feet of pipe).

- Remove paint containing ≥ 50 ppm PCBs on the portions of the exterior of the ATF's air induction system, including appurtenances (e.g., valves, flanges, fittings, etc.) that are not sheathed in the aluminum clad/asbestos-containing material (ACM) insulation.
- Maintain (and not disturb) the aluminum cladding and insulation, which forms a barrier to exposure to any PCB-containing paint that might remain on the exterior of the pipe.
- Implement an operation and maintenance plan (O&M plan – **Attachment F**) to periodically assess the condition of the piping for the purpose of determining replacement needs over time (refer to Section 4.4). As the piping is replaced, any PCB-containing paint associated with such piping shall be managed properly and disposed of as PCB Bulk Product Waste.
- Maintain the PCB M_L marker in appropriate locations, as well as the procedures regarding employee awareness and protection, and the management and disposal of PCB Bulk Product Waste. These elements are already in the 2012 Approval.

Essentially, all paint containing ≥ 50 ppm PCBs will be removed from the interior of the piping, and from any portions of the exterior of the piping system and appurtenances not covered by the aluminum clad/ACM insulation. Upon implementation of this Plan, the risk of exposure to any remaining paint on the piping system that might contain ≥ 50 ppm PCBs will have been abated.

GE believes that this Plan is the best risk management strategy. There will be no exposure to PCBs from the interior of the piping and PCB-containing paint on the exterior of the piping to which there may be a current potential for exposure, because such paint will be removed. The multi-layered, metal-sheathed insulation on the pipe, described in more detail in Section 4.2, will continue to provide a several inch thick fixed and rigid encapsulating barrier that prevents exposure to any PCB-containing paint that may remain on the exterior of the pipe.

This rigid encapsulating barrier exceeds the protection provided by the "double wash/rinse/paint" option authorized by USEPA for painted surfaces upon which ≥ 50 ppm liquid PCBs have been spilled [40 CFR § 761.30(p)]. GE recognizes that § 761.30(p) does not apply to the management of non-liquid PCBs embedded in the matrix of paint, and GE is not relying on § 761.30(p) as a legal basis for this plan. Rather, it is being referred to as a technical example to help support the conclusion that



the PCBs in the dried paint matrix that are covered by the several inch thick rigid encapsulating barrier do not pose an unreasonable risk (a barrier more robust than the double layers of contrasting paint set forth in § 761.30(p)).

Additionally, this plan avoids certain known risks related to removal and disposal of ACM insulation and PCB-containing paint as well as the associated technical and safety challenges posed by the size, location and design of the piping network (including a significant amount of work at elevated heights).

2. Background & Overview

2.1 ATF Operations

The ATF is a free-standing facility that contains two engine test cell compartments (referred to as Cells 43 and 44) where engines are mounted in closed cells during the testing phase. Cells 43 and 44 can be used either in a sea-level static mode or in an altitude/speed simulation mode. Through the use of a complex air induction piping network, compressed air may be introduced into the jet engine during testing to simulate speed. By adjusting the flow of compressed air within the test chamber, altitude conditions also can be simulated. The exhaust from the test compartments is routed through two stacks (one for each test cell compartment). The length of any particular test is dependent on the requirements set by the customer, and ranges from a few days to several months. It is important to note that the engine is not operated continuously during the test period. The engine may be operated for different lengths of time under different conditions and subject to periods of downtime while test data is analyzed by the project team.

The piping network consists of a series of primarily six-foot and eleven-foot diameter pipes constructed of 1/4-inch thick, and 3/8-inch thick specialty steel, respectively, that were pre-finished with paint on both the exterior and interior surfaces by the manufacturer/supplier of the piping network. The piping network, which spans a total length of approximately 1,800 linear feet, is encapsulated with a multi-layered insulation barrier consisting of a metal mesh base layer, rigid ACM millboard, and mineral wool, all covered by an aluminum jacket held in place with steel bands. This barrier is described in more detail in Section 4.2 of this Plan. Appurtenances on the piping network are painted, but are not covered with the encapsulating insulation barrier.

2.2 Interim Plan for Current Testing Operations

The interim remedial solution, proposed by GE and approved by USEPA, has been completed. The completed measures are as follows:

- The interior of the air induction piping has been double washed, double rinsed and double painted with contrasting colors of paint.
- GE employees and contractors working in the vicinity of the ATF have been notified of the presence of PCB-containing paint, and adjustments have been made to work practices. Employees have received PCB awareness training,

as well as training specific to new policies on personal protective equipment (PPE) requirements (e.g., Tyvek suits, hand, face, and respiratory protection) when working inside the air pipe.

- PCB M_L markers have been installed at appropriate locations, including all entrance points to the ATF.
- Indoor air testing has been conducted in accordance with the Air Monitoring Plan, and the results of such testing have been provided to USEPA.
- Additional measures were implemented to ensure continued compliance with the interim solution during current testing operations, including:
 - Protection and maintenance of piping insulation as an effective barrier to PCB-containing paint exposure.
 - Care taken to prevent damage to and contact with exposed paint on appurtenances.

3. Paint Removal Efforts

3.1 Introduction

This portion of the Plan describes the means and methods of removal for all exposed (i.e., not covered by the barrier described in Section 4.2 of this Plan) surfaces of the air induction pipe and associated appurtenances coated with PCB-containing paint. PCB-containing paint \geq 50 ppm will be removed from all the internal surfaces of piping and all exposed exterior surfaces of the air induction pipe and appurtenances.

On May 8, 2013, ARCADIS submitted the "Asbestos-Containing Material (ACM) Paint Sampling and Analysis" report to USEPA Region 5. The report summarizes ACM sampling and analyses of the paint from the ATF, which indicated the paint does not contain ACM. A copy of that report (as amended on June 18, 2013) is included as **Attachment D**. To the extent that any of the paint removal activities described in this section have the potential to disturb any ACM, the protective measures described in Section 4.3 will be implemented.

3.2 Paint Removal from the Interior of Pipe

Mechanical and/or chemical means will be used for removing paint from the interior of pipe. These efforts will consist of paint removal items such as wire wheel tools, hand scrapers, media blasting and/or chemical agents. The primary method of paint removal will be abrasives. However, to the extent that chemical strippers are used, only products that will not create exothermic reactions that would affect the chemical stability of the PCBs will be selected. The ingredients of the stripper that might be used have been reviewed (by reviewing the Material Safety Data Sheet and confirming with the manufacturer) and they do not pose a risk of creating an exothermic reaction (e.g., the stripper does not contain methylene chloride).

Paint removal operations will be completed in a contained environment ensuring PCB-containing paint does not leave the work zone inside the air pipe. Confined space entry teams will rotate in and out of the air pipe to ensure appropriate rest between work efforts. Confined space rescue teams, with required PPE (i.e., helmeted supplied air or half/full face respirator as required; disposable Tyvek suits, gloves, and booties), will be present and standing by for all permit-required confined space work.

Sections of the ATF piping network where paint removal is anticipated to occur will be sealed off to reduce the possibility of paint scrapings and residual paint leaving the work area. Paint removed from the steel pipe will be collected using dedicated shop

vacuums with high-efficiency particulate air (HEPA) filters. Containment areas will be placed under negative pressure and equipped with HEPA air filtration units. Following paint removal, exposed surfaces will be cleaned. Any materials collected from the cleaning efforts inside the air piping will be containerized into PCB marked drums and prepared for off-site disposal as PCB Bulk Product Waste.

The paint will be removed to meet the Visual Standard No 2, Near-White Blast cleaned surface finish, of the National Association of Corrosion Engineers (NACE) referred to in 40 CFR 761.79 (b)(3)(B).

3.3 Paint Removal from the Exterior of Pipe/Appurtenances

Removal of exposed (i.e., not encapsulated by the insulating barrier) paint on the exterior of the pipe and appurtenances will utilize the same mechanical and chemical removal methods described in Section 3.2. Containment structures will be utilized for all activities in order to reduce the possibility of paint scrapings and residual paint leaving the area. The containment structure will include a decontamination chamber attached to the entrance/exit for the removal and disposal of PPE during personnel egress following removal activities. These containment structures will be under negative air pressure. Following paint removal, exposed surfaces will be cleaned prior to removal of the containment structures. Any cleaning materials collected from the containment structure will be containerized in PCB marked drums and prepared for off-site disposal as PCB Bulk Product Waste. To the extent that these activities involve the disturbance of ACM, the applicable Federal and State asbestos regulations will be complied with, as discussed in more detail in Section 4.3 of this Plan.

For elevated portions of the pipe and appurtenances, work crews will construct and utilize elevated structures (i.e., scaffolding) to perform paint removal activities. These structures will follow OSHA regulations and site-specific policies for fall protection and working at elevated heights.

4. Pipe with ACM Insulation and Barrier

4.1 Introduction

This portion of the Plan describes provisions for removing specific portions of air induction pipe, and the operation and maintenance plan for the pipe that will remain in place.

4.2 Description of the Insulating Barrier

Approximately 1,500 feet of the ATF piping network is protected and covered by a multi-layered insulation barrier and aluminum sheathing, effectively encapsulating any PCB-containing paint on the exterior surface of the pipe. This encapsulation provides a barrier preventing any potential contact with the PCB-containing surface, thus preventing any risk to human health or the environment.

This barrier, depicted in Figure 1, consists of the following (interior to exterior):

- “High chairs” or “Spacers” of reinforced steel support the insulating barrier and create 2-5 inches of air space between the exterior of the pipe and the first layer of the barrier.
- The first component of the barrier, 2-5 inches from the pipe, is a double layer of galvanized metal mesh.
- The second layer is comprised of rigid asbestos-containing millboard that is 0.25 to 0.5 inches thick.
- The third layer is mineral wool 2-3 inches thick.
- The final layer is rigid aluminum cladding.

Figure 1 - ATF Multi-Layered Barrier - Detail

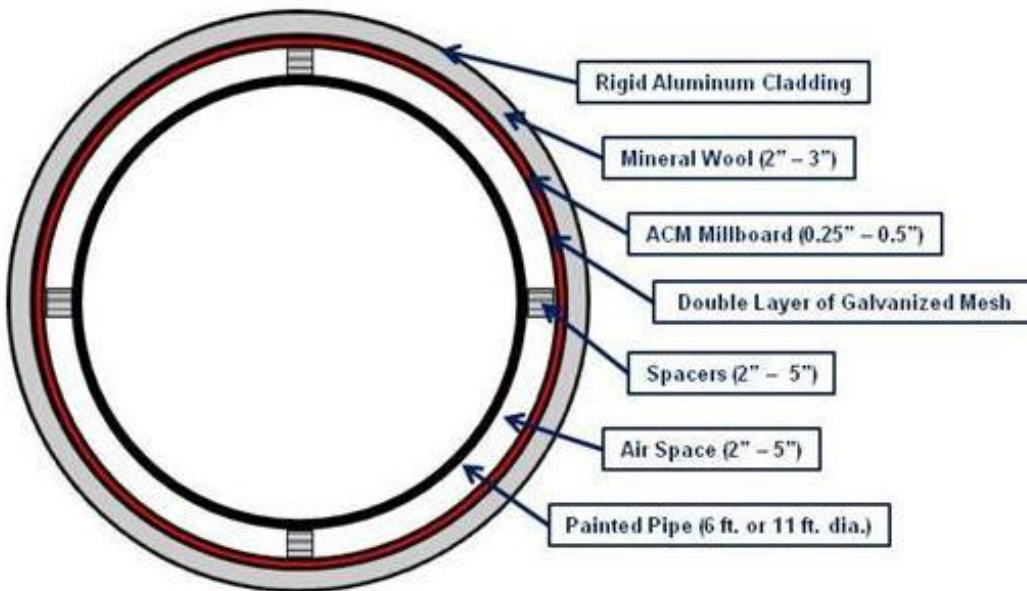

Pictures illustrating the barrier are provided in **Attachment E**. This multi-layered, metal-sheathed insulation on the pipe provides a fixed and rigid encapsulating barrier that prevents exposure to any PCB-containing paint that may be present on the exterior of the pipe. GE will inspect and maintain the existing insulation and barrier found on portions of the air pipe to ensure it remains in good condition. The O&M Plan is outlined in Section 4.4 and included in Attachment F.

4.3 Pipe Replacement Plans (Including ACM Management Procedures)

Selected elevated portions of the six foot diameter pipe will be replaced with new steel piping. The piping scheduled for removal and replacement is up to 300 feet in length and located on the western side of the ATF.

The general procedure for pipe removal is as follows:

- Prior to conducting removal activities, GE's designated contractor will submit a State of Ohio Department of Health (ODH) Notification of an Asbestos Abatement Project, as required under State of Ohio Administrative Code

(OAC), Chapter 3701-34, due to the presence of ACM in the encapsulating barrier.

- Pipe insulation will be removed from elevated locations at varying intervals (dependent on field conditions) while the pipe remains in-place. The purpose of this step is to expose the portion of the pipe that will be cut in order to remove it. The metal jacketing covering the ACM pipe insulation will remain in place where the pipe insulation is not removed. Removal activities will be conducted in asbestos regulated work areas by constructing negative pressure enclosures (NPEs) around the piping using scaffolding units. The remaining edges of exposed ACM pipe insulation will be encapsulated and sealed with wet amendable cloth to prevent asbestos fiber release. Alternatively, ACM pipe insulation will be abated along an entire section of piping (in place) using the NPE procedures described above, followed by mechanical cutting and lowering the pipe to the ground via crane (following the ACM abatement).
- In the event any “hot work” is required for pipe removal, paint will be removed from the interior and exterior of the pipe to prevent any separation of paint during cutting activities.
- In general, where ACM remains on the pipe as part of the dismantlement operations, pipe sections will be cut using mechanical means and lowered by crane to the ground onto polyethylene sheeting inside an asbestos regulated work area. Once the section of pipe is secured in-place on the polyethylene sheeting, an NPE will be constructed around the sections of pipe for stripping the remaining ACM pipe insulation.
- Once the encapsulating barrier has been removed, the pipe segments will be sized and processed for disposal as PCB Bulk Product Waste in accordance with Section 5, with the option of managing as scrap metal sections of pipe (or appurtenances) from which the paint has been removed. Waste generated as part of ACM removal activities will be disposed of as PCB-containing ACM waste in accordance with Section 5.

Since the encapsulating barrier contains ACM, additional considerations must be addressed as part of these work activities. Specifically:

- ACM insulation removal will be performed by a ODH licensed Asbestos Hazard Abatement Contractor (AHAC) in accordance with all local, state, and federal regulations, including but not limited to, 40 CFR 61 Subpart M, 29

CFR 1926.1101, and the ODH OAC § 3701-34 and State of Ohio Environmental Protection Agency OAC § 3745-20.

- An Ohio Asbestos Hazard Evaluation Specialist (AHES) will be on-site during ACM removal activities to perform inspections of each asbestos regulated work area prior to and following abatement activities to ensure that work area preparations and removal activities are in compliance with federal and state regulations and project specific requirements. Following final visual inspection of the regulated area, the AHES will collect clearance air samples in accordance with OAC § 3701-34-1 prior to allowing the NPE to be dismantled.
- All persons entering the asbestos regulated work areas shall adhere to the PPE requirements as established by OSHA 29 CFR 1926.1101; specifically Class I operations. The AHAC will be responsible for conducting its own personnel exposure monitoring to demonstrate that they are using the appropriate level of PPE to comply with the OSHA Permissible Exposure Limits (PELs).

4.4 Operation and Maintenance Plan For Pipe Encapsulated By The Insulating Barrier

4.4.1 Introduction

With the exception of the pipe removal project described above, GE plans to maintain the balance of the piping that is encapsulated with the insulating barrier. This will prevent any exposure to possible PCB-containing paint that is on the surface of the pipe, and will abate the risks associated with a wholesale removal of all of the pipe and the ACM-containing insulation. In addition, the O&M Plan (Attachment F) will serve as the framework for replacing the pipe over time, which necessarily will result in the removal of any PCB-containing paint on its surface.

A summary description of the piping that will continue to remain encapsulated with the insulation is as follows:

- Approximately 1,500 feet of piping (including 18-inch, 36-inch, 6-foot and 11-foot diameter).
- Approximately 310 feet of this piping is located exterior to the ATF at elevated heights (20-25 feet above grade).

- Approximately 160 feet of piping is semi-enclosed. It runs between the air inlet concrete structures and the main building wall of the ATF. This piping is located beneath elevated steel piping and the infrastructure used to support that elevated piping.
- The balance of the remaining piping, approximately 1,030 feet, is located inside the ATF.

As described in detail in Section 4.2 above, the insulating barrier completely prevents any exposure to PCB-containing paint that may be on the surface of the pipe underneath the barrier. This rigid encapsulating barrier far exceeds the protection provided by the “double wash/rinse/paint” option authorized by USEPA for painted surfaces upon which > 50 ppm liquid PCBs have been spilled [40 CFR § 761.30(p)] (as noted above, the reference to § 761.30(p) is for technical comparison purposes only, and is not being cited in this Plan as legal authority for the continued use of the encapsulated pipe). Since USEPA already has found that liquid PCBs on the surface of painted surfaces do not pose an unreasonable risk if covered by two layers of paint, then it is reasonable to conclude that non-liquid PCBs contained in a matrix of dried paint, and covered by a several inches thick rigid and metal-clad barrier, do not pose an unreasonable risk. On the other hand, for the reasons described below, removing all of the PCB-containing paint from the exterior of all of the piping does create risks.

The ATF piping network is a very complex system, with much of the system at significant heights and characterized by various turns and angles as it snakes its way through the ATF. Indeed, the ATF roofing systems and building walls were manufactured around the piping system, and the system is intertwined with the infrastructure of the ATF. The pictures in Attachment E are a few examples that illustrate the complexity of the system.

As described above, approximately 310 feet of piping is exterior to the ATF, but at a height of 20-25 feet from the ground. Any substantive work at these heights will require scaffolding and the use of cranes, along with the measures necessary to manage ACM (including enclosing the work areas at height). In addition, paint removal (via media blast) at these heights poses significant safety management challenges due to the force required by media blasting to remove the paint from the pipe; it is the equivalent pressure and force of holding a fire hose with blasting pressures exceeding 100-120 pounds per square inch, while wearing protective clothing and a helmet tethered to breathing hoses, all on a scaffold.

The remaining semi-enclosed piping (160 feet) is comprised of 11-foot diameter pipe fabricated within the concrete walls of the two inlet stacks and the concrete walls of the engine test cells. In addition, an elevated piping network and structural supports above the 11-foot piping (exterior to the building) would require partial building demolition in order to remove or replace the pipe.

Approximately 1,030 feet of piping located within the ATF (enclosed within walls, under roof) is in tight confines, “weaving” through the building (at elevation and at grade) before exiting the building to transfer air to the headworks (or inlet) of the two engine test cells. Based on the duct layout, it appears that the piping network was constructed prior to the construction and installation of the walls and roof of the ATF. Although there are two fairly straight sections of piping within the ATF building (55 feet of 3-foot diameter pipe; 55 feet of 6-foot diameter pipe), one is elevated and both would require partial building demolition and relocating the electrical panel system for the building in order to gain access for pipe replacement. All interior piping currently is protected by the building’s walls and roof.

Therefore, determining the presence and extent of any PCB-containing paint on the exterior of these portions of the encapsulated piping, and removing any such paint, should it be detected, effectively would require the demolition of portions of the ATF structure followed by piecemeal dismantling of the entire piping system since many of the pipe surfaces are not accessible in-place (e.g., covered by other piping or building infrastructure). Demolition of the structure and dismantling the piping system poses the following risks:

- Managing ACM removal in a much more complex setting than is presented with the removal of up to 300 feet of pipe described in Section 4.3 (which is itself not a simple project).
- Much of the work would have to be conducted at significant elevations, creating occupational safety risks that would have to be managed carefully.
- The risks posed by working at elevation are compounded by the complexity of the piping system and how it is intertwined with the infrastructure of the ATF.
- Access to significant portions of piping within the ATF structure will require demolition of roof and walls to gain access to the piping network.

Therefore, removing the protective barrier and any PCB-containing paint that may be beneath that barrier will pose immediate known risks. This is in sharp contrast to maintaining the barrier, which not only poses no additional risks, but actually prevents exposure to any PCB-containing paint, and thus eliminates risk. In addition, dismantling certain portions of the piping would require the removal and subsequent replacement of the infrastructure of the ATF, which further would reduce the availability of the ATF for testing jet engines, including jet engines used for purposes of national defense.

4.4.2 Piping Network Inspections

GE will conduct monthly inspections of the air induction piping network in addition to the monthly PCB M_L marker inspections. The ATF piping network inspection will include a visual inspection of the encapsulating barrier to verify that it is free from damage, including but not limited to, corrosion, water damage, cracks, and/or breakage. These inspections will be performed along all accessible portions of the approximate 1,500-foot length of the encapsulated piping. Where necessary, due to elevated piping and/or tight confines, GE will use alternate means (including, but not limited to, man lifts, confined space entry permit, etc.) to gain limited access to the pipe network in order to complete the monthly pipe inspection. Any damage will be identified on an inspection log and either will be repaired promptly or addressed as part of a pipe or barrier replacement project, described in Section 4.4.3.

In addition, prior to conducting an engine test (but no less than monthly), GE conducts a Foreign Object Debris (FOD) inspection of the entire interior of the piping network. In the event that any pipe damage is identified, GE will follow the same procedures as outlined above (i.e., complete an inspection log; promptly repair or address per Section 4.4.3).

In addition to routine monthly visual inspections, the ATF piping network, including the encapsulating barrier, will be subject to a condition assessment by a third-party engineering firm every five years.¹ This assessment will include the following elements:

¹ American Petroleum Institute – API 570 – “Piping Inspection Code: Inspection, Repair, Alteration, and Rerating of In-service Piping Systems” – 3rd Ed., November 2009, Class 4 rated pipe (non-flammable, non-toxic), which is the class of pipe used at the ATF, requires no inspection interval. However, as a conservative approach, inspections will be conducted on a 5-year interval consistent with Class 1 rated pipe (flammable or pressurized systems).

- A comparison of current conditions to the design parameters of the piping network, including material specifications, design diameters, and wall thickness.
- An evaluation of the operating parameters of the piping network, including design temperature and pressures.
- A description of any modifications, repairs, or significant visual inspection findings since the last assessment.
- An assessment of the piping network's fitness for continued use (e.g., greater than 50% of the pipe wall thickness remains – continued use of the pipe is satisfactory).
- Any recommendations regarding the repair or replacement of portions of the piping system.

The findings from the third-party condition assessment will be summarized in a final report that will be maintained pursuant to Section 8, and be available for USEPA review. The need for any maintenance, repair, or replacement activities identified as a result of the condition assessment will be addressed as a pipe or barrier replacement project as described in Section 4.4.3.

4.4.3 Pipe / Barrier Repair and Replacement

In the event that the existing encapsulating barrier is damaged and must be replaced, appropriate GE Environmental Health and Safety (EHS) personnel will oversee the replacement operations. In general, the repair or replacement of the encapsulating barrier will be performed by an ODH licensed AHAC, with appropriately certified personnel, to perform the abatement work. Work will be conducted in accordance with Section 4.3. Under no circumstances will torch cutting or flame emitting devices be used when removing or repairing the insulating barrier. Waste generated by the barrier or PCB painted pipe repair or removal activities will be managed in accordance with Section 5.

Future pipe replacement efforts, including those arising from the inspections and recommendations described in Section 4.4, will be coordinated and overseen by GE EHS personnel. USEPA will be notified of any pipe replacement project at least 60 days prior to the commencement of such project. Such a notification will identify the portions of the pipe intended to be replaced and the process for removing such pipe,



**Long-Term Remediation Plan for
the Altitude Test Facility (ATF)**

GE Aviation
Cincinnati, Ohio

including applicable measures to protect human health and the environment. In the event of an emergency condition requiring a major repair or replacement of pipe, the work will be conducted immediately; USEPA will be notified of the work within 1-2 business days. Minor repairs to the pipe will be completed per GE's on-site standard operating procedures (SOPs) with no USEPA notification. Prior to disconnecting the pipe from the network, the encapsulating barrier surrounding the disconnection point will be abated per the procedure outlined in Section 4.3. All waste generated as a part of pipe replacement activities will be managed in accordance with Section 5. Documentation (e.g., waste manifests, bills of lading and/or certificates of disposal) will be maintained by GE as part of the record keeping program described in Section 8.

The overall condition of the ATF building is good and the building is regularly maintained. There are no additional renovations, retooling or demolition plans at the ATF building beyond the pipe replacement project currently being conducted.



5. Waste Management

Wastes generated from the activities subject to this Plan will be treated as PCB Bulk Product Waste, and disposed of in accordance with Toxic Substances Control Act (TSCA) requirements, with the option that metal from which paint has been removed may be managed as scrap metal. In addition, any asbestos waste generated will be handled and disposed of in accordance with ACM regulations, as well as TSCA requirements.

Maintenance of all records and documents will be kept in one centralized location as required by 40 CFR § 761, including, but not limited to, the records required under Subparts J and K. All records will be available for inspection by authorized representatives of the USEPA.

6. Work Schedule

The interim jet engine testing being conducted in accordance with the 2012 Approval will be completed by July 31, 2013. This Long-Term Plan will be completed by December 31, 2014 pursuant to the following schedule:

- The removal and replacement of up to 300 feet of the air induction system piping will be completed by February 1, 2014.
- The removal of paint containing > 50 ppm PCBs located on the interior of the remaining portions of the air induction system piping (approximately 1,100 feet of pipe) will be completed by February 1, 2014.
- The removal of paint containing > 50 ppm PCBs on the portions of the exterior of the ATF's air induction system piping and appurtenances that are not sheathed in the aluminum clad/ACM insulation will be completed by no later than December 31, 2014.
 - Jet engine testing will re-commence only when paint removal from the interior of the piping is completed. This currently is anticipated to occur ahead of the scheduled February 1, 2014 date, which will allow engine testing to re-commence in January, 2014. No jet engine testing will occur until the remediation of the interior surfaces, and the removal and replacement of the 300-foot section of the air induction system piping is completed. Air monitoring will be conducted in accordance with Attachment C before jet engine testing re-commences. In the event that the work on the exterior of the piping and appurtenances is not completed by the time jet engine testing re-commences, the remainder of the work will be completed no later than December 31, 2014. Any engine testing occurring between the time that the work on the interior of the pipe is completed and December 31, 2014 will be conducted in accordance with the conditions in the 2012 Approval.

7. PCB Awareness

Pursuant to the 2012 Approval, GE installed more than forty PCB M_L markers at appropriate locations throughout the ATF. The markers serve to inform personnel entering and/or performing work in the facility that there are PCBs present that require special handling and disposal in accordance with 40 CFR § 761. The markers are posted at exterior entrances, access points, and exterior pipe locations (e.g., elevated stairways, catwalks, overhead doors, entrances, ductwork, etc.). PCB M_L markers will be maintained throughout the execution of the Plan. Following the completion of the paint removal activities of the Plan, the location and quantity of PCB M_L markers will be updated. Where PCB M_L markers are to remain, GE will continue to conduct monthly inspections of the markers to verify that each marker is intact, in good condition, and that all information, including contact name and phone number, is visible.

In addition to installing PCB M_L markers throughout the ATF, GE has implemented a PCB awareness program for GE employees and contractors working in the vicinity of the ATF. This program consists of notifying personnel of the presence of PCB-containing paint on the ATF air induction system piping and includes a training session for targeted personnel who perform work activities in and around the ATF (e.g., maintenance, inspections, etc.). Approximately twenty two (22) people (Test Operations, Engineers, Maintenance, etc.) work at different times within the ATF buildings, with each worker totaling approximately 400 hours annually. Most of those work activities involve monitoring engine test runs from control rooms, while work within the engine test cells includes test preparation, equipment inspection and maintenance, and test shutdown. The training session includes an overview of PCBs, the regulatory considerations surrounding their use, and the nature and extent of PCB concentrations detected in the ATF. Furthermore, the training covers the PPE SOP and waste management SOP for the ATF.

Although the implementation of the Plan will eliminate the risk of exposure to any PCB-containing paint, GE will continue its PCB awareness program as a preventative measure and for any future pipe maintenance and/or replacement with the potential to expose personnel to PCB-containing paint. Training sessions will be held for new employees and annual refresher training will be provided to existing workers who work within and in the vicinity of the ATF.

8. Maintenance Record Keeping

GE shall maintain records relating to the maintenance of the ATF air induction system described above. These records will include, but will not be limited to, the following:

- PCB M_L marker inspection logs.
- PCB awareness training records.
- Pipe inspection logs.
- Reports of piping system assessments conducted by the third-party engineering firm.
- Updated as-built drawing of the ATF system, revised as pipe changes/replacements occur over time.
- Copies of manifests, bills of lading and/or certificates of destruction for pipe removal/replacement, as applicable.

9. Reporting

9.1 Final Completion Report

GE will submit a single Final Completion Report to the USEPA Region 5 PCB Coordinator within 120 days of the completion of activities subject to this Plan (with the exception of on-going operation and maintenance activities described in Section 4.4), which also will include the information required by Condition 22 of the 2012 Approval (GE believes that it may simplify USEPA's review to receive one report rather than two). At a minimum, the Report will include the following:

- Summary package of data tables, figures, and laboratory analytical documentation for sampling that has been conducted at the ATF for the purpose of PCB-containing paint remediation.
- Indoor air sampling analytical results, including copies of accompanying analytical chains of custody and field and laboratory quality control/quality assurance checks.
- A brief narrative describing the activities performed, including any deviations from the Plan or GE 2012 Submission and Approval. This narrative will include the method employed during interim cleanup, paint removal, and pipe removal/replacement activities; the location, quantity, and extent of paint removal; the location of pipe removal; quantity of waste generated; waste disposal documentation; PPE worn; methods and devices for ensuring health and safety during all work activities; and decontamination procedures.
- Copies of all waste manifests, bills of lading, and/or certificates of disposal, with an associated summary table broken down by waste type.

9.2 Annual Report / Condition Assessment Report

GE will submit an annual letter report to the USEPA Region 5 PCB Coordinator, summarizing pipe removal and replacement projects from the previous year, if any (report to be submitted by March 15th of the subsequent year). Annual reports will continue to be submitted to USEPA until the remaining piping network has been replaced or the ATF facility undergoes decommissioning/demolition (whichever occurs first). In addition, the third party pipe condition assessment reports will be submitted to USEPA as an attachment to the annual report (every 5 years).



Attachments



Attachment A

GE Aviation Short-Term Section
761.62(c) Submission (November
16, 2012)



GE Aviation

Tony Aiello
Vice President & General Manager
Assembly, Test & Overhaul CoE

One Neumann Way
Mail Drop G101
Cincinnati, OH 45215
USA

T +1 513 243 6800
F +1 513 672 0912
tony.aiello1@ge.com

November 16, 2012

VIA FEDERAL EXPRESS AND E-MAIL

Susan Hedman
Regional Administrator
U.S. EPA Region 5
77 W. Jackson Blvd
Chicago, IL 60604

RE: GE Aviation Short-Term Section 761.62(c) Submission

Dear Administrator Hedman:

This is a petition, made pursuant to 40 C.F.R. § 761.62(c), by GE Aviation, an operating division of the General Electric Company ("GE"), for an interim risk-based alternative cleanup solution to address the presence of PCB-containing paint that was recently discovered on the inlet air induction system at the Altitude Test Facility ("ATF") at GE's jet engine manufacturing facility in Cincinnati, Ohio.

These interim measures will allow GE to conduct four currently scheduled jet engine tests in a manner that does not pose an unreasonable risk to human health and the environment. Upon completion of these four tests, and in any event no later than July 31, 2013, any further operations at the ATF will be in accordance with an agreement with U.S. EPA with respect to a permanent plan to address the PCB-containing paint in the ATF.

This interim solution will also allow GE to meet short-term commitments to conduct jet engine tests for the U.S. Navy that are part of a program to resolve reliability issues that are impairing the operational capability of certain military aircraft currently in service. These commitments include a test scheduled for early December 2012. A letter from the Navy indicating the importance of these tests will be forwarded under separate cover. For this reason, GE seeks approval from U.S. EPA in time to be able to initiate the first of these tests by December 3, 2012.

The central elements of this proposed interim solution are:

- The interior of the inlet air induction piping network will be double washed, double rinsed and double painted, consistent 40 C.F.R. § 761.30(p).

- PCB M_L signs will be installed at appropriate locations, including entrance points to the ATF.
- The exterior of the inlet air induction pipes are, with the exception of certain fittings and appurtenances, covered with a multi-layered protective barrier, completed with an aluminum sheathing. This covering will be maintained and the piping marked appropriately.
- GE employees and contractors have been made aware of the presence of PCB-containing paint on the inlet air induction pipes, and work practices are in place to limit their exposure to such paint.
- GE has implemented an operations plan for the management of wastes (e.g. PPE, etc.) as potentially PCB-containing for storage and disposal.

The period during which this interim solution would be authorized would end on July 31, 2013.

1. Description of the ATF

The GE Aviation facility in Cincinnati, Ohio designs, develops, manufactures and tests jet engines for military and commercial customers. The facility operates an engine test facility known as the Altitude Test Facility (ATF). The purpose of the ATF is to test jet engines in conditions that simulate the use of the engines at a wide range of altitudes (up to 30,000 feet) and speeds (over 2,000 mph). The ATF is one of only two facilities that exist in the US that has these capabilities (the other is owned and operated by the US Air Force).

The ATF is a free-standing building that contains two engine test cell compartments. Engines are mounted in these compartments, which are closed during the testing phase. Through the use of a complex air induction piping network, compressed air is introduced into the jet engine during testing to simulate speed. By manipulating the flow of compressed air within the test chamber, altitude conditions also are simulated. The exhaust from the test compartments is routed through two stacks (one for each test cell compartment). The length of any particular test is dependent on the requirements set by the customer, and can range from a few days to several months. It is important to note that the engine is not operated continuously during the test period. It is operated for different lengths of time under different conditions and subject to periods of downtime while analysis is conducted by the project team.

The air induction piping network consists of a series of primarily six-foot diameter piping constructed of ½-inch thick specialty steel that was pre-finished with paint on both the exterior and interior surfaces by the manufacturer/supplier of the piping network. The piping network, which spans a total length of approximately 1,000 linear feet, is encapsulated with a multi-layered insulation consisting of metal mesh, mineral wool, and an asbestos-containing material, all covered by an aluminum jacket held in place with steel bands. Valves, certain pipe joints, and other appurtenances on the piping network are not covered with the insulation.

To avoid the ingestion of foreign objects or debris ("FOD") by the jet engines during testing, portions of the air induction piping network are periodically inspected to verify that there is no peeling paint or other material in the pipes that might be drawn into the engines when the compressed air is pushed through the system. These FOD inspections are typically conducted once or twice a week during a testing cycle, and take approximately 1 – 2 hours to complete.

2. PCB Sampling Data

On October 26, 2012, GE received sampling data indicating that the paint originally used on the ATF air induction piping network by the manufacturer of the network contained ≥ 50 milligrams per kilogram (mg/kg) PCBs. GE informed U.S. EPA of this issue on November 1, 2012, and provided U.S. EPA with a summary of the PCB sampling data on November 6, 2012.

GE sampled paint on both the interior and exterior of the piping, taking both wipe and bulk (i.e., paint chip) samples. In addition, air sampling was conducted within the piping (during static conditions) and the ATF building. The sampling and analytical work was conducted in accordance with U.S. EPA-approved protocols. The results of the sampling, including the QA/QC documentation, are included in Attachment A to this submission.

The results of the PCB data are summarized as follows:

Interior Pipe Surfaces

- 53 wipe samples - results ranging from non-detectable (ND) to 10.0 micrograms per 100 square centimeters ($\mu\text{g}/100\text{ cm}^2$).
- 30 paint chip samples - results ranging from ND to 42,000 mg/kg.

Exterior Pipe Surfaces

- 42 wipe samples - results ranging from ND to 2,900 $\mu\text{g}/100\text{ cm}^2$.
- 29 paint chip samples - results ranging from ND to 100,000 mg/kg.

Air Monitoring

- 2 locations inside the pipe – ND and 125 nanograms per cubic meter (ng/cm^3).
- 2 locations in the ATF - ND and 83.3 ng/cm^3 .

The concentration of PCBs in the paint and the nature of the operations in the ATF indicate that these are so-called "non-liquid" PCBs that were present in the paint at the time of manufacture, not PCBs spilled or released onto the paint.

3. Interim Plan For Operations And Managing The PCB-Containing Paint

GE is taking the following actions to prevent or reduce exposures to the PCB-containing paint on the ATF air induction piping:

- The interior of the air induction piping network is being double washed, double rinsed, and double painted (with contrasting colors of paint).
- The aluminum-clad exterior insulation on the piping system will be maintained.
- The PCB M_L mark will be placed at appropriate locations on the piping system and at entrance points to the ATF.
- GE employees have already been made aware of the presence of PCBs in the paint.
- Work practices have been adopted to minimize the potential for exposure to PCBs, including training and the use of PPE (e.g., Tyvek suits and respiratory protection) for employees who conduct the periodic FOD inspections the maintenance activities related to the piping system.
- Any waste generated by the double wash/double rinse/double paint process, as well as any waste generated by FOD inspections or maintenance activities involving the piping, will be managed and disposed of as either PCB Remediation Waste or PCB Bulk Product Waste, as appropriate.
- The engine testing operations GE anticipates conducting in accordance with this interim solution will involve four jet engine altitude tests (i.e., tests where the various flight altitudes will be simulated during the test):

Engine	Purpose	Estimated Duration	Required Completion Date
F414	Collect data to support design improvements to prevent engine stalls that have been the second leading cause of unscheduled engine removals in the F-18 fleet.	2.5 months (approx. 75 hours of test run time)	1/15/2013
F414	Assurance testing to validate solutions to the fourth leading cause of unscheduled engine removals in the F-18 fleet.	1 month (approx. 25 hours of test run time)	3/9/2013
LEAP Core	Testing required to optimize the performance, operability and aero-dynamics of engine operation to ensure durability and reliability for entry into service application.	2.5 months (approx. 100 hours of test run time)	6/15/2013
F414	Test technology that will eliminate a failure mode for the engine, and also support planned engine design enhancement to improve F-18 mission capability.	3 months (approx. 487 hours of test run time)	7/15/2013

The first test is particularly sensitive and time-critical, since it is part of an important effort to determine the cause of, and prevent, engine stalls on the F-18 fleet.

GE is proposing an end date of July 31, 2013 to allow for the possibility of some schedule slippage on these tests, which in our experience frequently occurs due to the highly complex nature of these engines during research, development and analysis, as well as changing customer requirements.

4. The Interim Plan Will Not Pose An Unreasonable Risk

GE believes that the measures described above will prevent any unreasonable risk associated with the PCB-containing paint on the air induction piping network during the four jet engine altitude tests that will be conducted between December 3, 2012 and July 31, 2013.

- There is very low likelihood of exposure to the PCB-containing paint on the exterior of the piping because it is covered with the aluminum-clad insulation.
- Any maintenance associated on the pipes will be conducted pursuant to defined work procedures that will protect against exposure to PCBs and require the proper management and disposal of waste.
- Any PCB-containing paint on the interior of the piping will not pose an unreasonable risk because:
 - The surface will have been cleaned and then coated with two layers of paint. Therefore, there should not be any exposure of concern to PCBs on the surface of the pipe. Further, even before the washing and painting, the highest level PCB level detected on the interior surface of the pipe was 10 µg/100 cm², which is consistent with the decontamination standard for unpainted non-porous surfaces that U.S. EPA has already found does not pose an unreasonable risk. The cleaning and painting of the piping surface should provide more protection than what is already allowed under the PCB regulations pursuant to 40 C.F.R. § 761.30(p), since the situation at the ATF involves non-liquid PCBs.
 - Exposure to the interior of the piping will be very limited, with trained GE employees, using PPE, entering the piping system for approximately 2 – 4 hours/week during any particular testing regime, ending in July 2013.
- GE employees have already been made aware of the presence of PCB-containing paint on the air induction system piping, PCB M_L marks will be a regular reminder of that fact, and they will also be trained to take proper precautions when working around or on the piping system.
- The air sampling demonstrated that the PCB concentrations in the air, both inside the piping and in the ATF generally, are well below any standard considered by U.S. EPA in the context of regular occupational exposures (e.g., 40 hour/week exposure over several years). For example, U.S. EPA has suggested a standard of 450 ng/cm³ for school teachers exposed 40 hours/week, 9 months/year. The highest level measured in the ATF itself is 83.3 ng/cm³, with 125 ng/cm³ measured inside the piping network (where the exposure might be only 2 – 4 hours/week, to trained workers wearing PPE, and only then during periods when tests are being run).
- The engine tests themselves will not disturb the PCB-containing paint in or on the air induction piping system. The engines are mounted in the test cell compartments, a process that does not involve working on the piping system. Further, the periodic

FOD inspections of the piping are intended to identify, among other things, any peeling paint to avoid it being ingested by the engines during the tests. Given that the piping will have just been painted with two coats of paint that does not contain PCBs, GE does not anticipate that there will be any peeling paint between now and July 31, 2013 and, if there is any, it will not be PCB-containing paint.

- Limiting the operations to four altitude tests, with an end date of July 31, 2013, will also serve to avoid any significant exposure to PCBs.
- Any PCB Bulk Product Waste generated at the ATF will be properly managed and disposed of in accordance with TSCA requirements.

5. Conclusion

GE believes that conducting four altitude engine tests at the ATF between now and July 31, 2013, in accordance with the conditions proposed in this submission, will not pose an unreasonable risk to human health or the environment. Accordingly, GE requests that U.S. EPA grant this petition for an interim solution, if at all possible by December 3, 2012. GE also looks forward to promptly initiating discussions with U.S. EPA regarding the longer-term solutions for the PCB-containing paint at the ATF.

Please do not hesitate to contact John Rumpf, Executive Counsel for Environmental Affairs at GE Aviation, at (513) 243-4256 or Christopher Bell at Sidley Austin LLP at (713) 315-9008 if you have any questions.

Sincerely,



Tony Aiello
Vice President, Assembly, Test & Overhaul

Enclosure

cc: Peter Ramanauskas, Regional PCB Coordinator, U.S. EPA Region 5
Susan Perdomo, Counsel, U.S. EPA Region 5
John Rumpf, Executive Counsel for Environmental Affairs, GE Aviation
Christopher Bell, Sidley Austin LLP



Attachment B

USEPA Region 5 December 19,
2012 Conditional Approval Letter



UNITED STATES ENVIRONMENTAL PROTECTION AGENCY
REGION 5
77 WEST JACKSON BOULEVARD
CHICAGO, IL 60604-3590

REPLY TO THE ATTENTION OF:

L-8J

DEC 19 2012

Mr. Tony Aiello
Vice President, Assembly, Test & Overhaul
GE Aviation
One Neumann Way
Mail Drop G101
Cincinnati, Ohio 45215

Re: GE Aviation Short-Term Section 761.62(c) Submission

Dear Mr. Aiello:

This is in response to the General Electric (GE) petition (Submission) dated, November 16, 2012, for an interim risk-based alternative cleanup solution to address the presence of Polychlorinated Biphenyl (PCB) containing paint discovered on the inlet air induction system at the Altitude Test Facility (ATF) at GE's jet engine manufacturing facility in Cincinnati, Ohio.

Under TSCA §6(e), use of PCBs is banned unless specifically authorized or excepted by regulation. Authorizations are provided for under 40 CFR §761.30 and exceptions appear at §761.20. Use of any PCBs not authorized or excepted under these rules is prohibited in the United States. The ATF site contains PCB paint that exceeds the allowable levels under the federal PCB regulations at 40 Code of Federal Regulations (CFR) §761.20(a) and §761.62. Therefore, use of the PCB paint at the ATF is not permitted as it is not an authorized or excepted use under 40 CFR §§761.20 and 761.30.

GE requests an approval to address PCB contamination at the ATF under 40 CFR §761.62(c) for the limited purpose of conducting a small number of engine tests. In support of this request for approval, the submission provides characterization data the company previously collected at the site and presents a proposal for interim measures allowing GE to temporarily conduct four scheduled jet engine tests on behalf of the Department of the Navy in a manner that will not pose an unreasonable risk to human health and the environment during the duration of the tests, and until such time that GE can permanently remove the PCB containing paint from the inlet air induction system. Furthermore, GE provided documentation prepared by the Department of the Navy, dated November 21, 2012, requesting that GE expeditiously resume the scheduled engine tests to address safety of flight and engine reliability issues and promote the operational readiness for certain Navy aircraft. The United States Environmental Protection Agency considered the Navy's flight safety and operational readiness needs in reviewing GE's submission.

GE specifically proposes the following activities under this interim action:

- The interior of the inlet air induction piping network will be double washed, double rinsed and double painted, consistent with 40 CFR §761.30(p).
- PCB M_I signs will be installed at appropriate locations, including entrance points to the ATF.
- The exterior of the inlet air induction pipes are, with the exception of certain fittings and appurtenances, covered with a multi-layer protective barrier, completed with aluminum sheathing. This covering will be maintained and the piping marked appropriately.
- GE employees and contractors have been made aware of the presence of PCB containing paint on the inlet air induction pipes and work practices are in place to limit their exposure to such paint.
- GE has implemented an operations plan for the management of wastes (e.g., PPE, etc.) as potentially PCB-containing for storage and disposal purposes.

GE requested and proposed that this interim solution be authorized only for the duration required to complete the scheduled jet engine tests (i.e., ending on July 31, 2013). Based on the EPA's review of the information provided in the Submission and subsequent technical discussion with GE's contractor, Arcadis, EPA finds that the proposed interim encapsulation of PCB-contaminated paint should effectively prevent direct exposure of these PCB surfaces to building users only during the four scheduled jet engine tests requested by GE on behalf of the Department of the Navy and, thus, should be protective of human health and the environment during these limited testing periods. Therefore, EPA approves the proposed interim action in accordance with the federal PCB regulations codified at 40 CFR §761.62(c) authorizing the Regional Administrator to approve a method to dispose of PCB Remediation Waste if it is found that the method will not pose an unreasonable risk of injury to human health or the environment. EPA emphasizes that this approval is for GE to conduct the proposed interim action only and this approval will expire on July 31, 2013. GE shall propose a long-term solution to EPA for the removal and disposal of the PCB Bulk Product waste paint, as described in Condition 17 of Attachment 1. EPA reserves its right to require additional investigation or mitigation measures at the ATF.

GE may proceed with its interim project in accordance with 40 CFR §761.62, the submission, and this approval, subject to the conditions of Attachment 1.

GE is responsible for ensuring continued compliance with all applicable provisions of the Toxic Substances Control Act (TSCA), the federal PCB regulations, and the conditions of this approval. Any departure from the conditions of this Approval or the Submittal must receive prior written authorization from this office. Further, this approval does not relieve GE from compliance with any other federal, State, or local regulatory requirements. This approval does not preclude EPA from initiating any enforcement action, including an action seeking civil penalties, suspension or termination of the approval for any violation, or requiring additional cleanup should GE fail to abide by this approval.

If you have any questions regarding this approval, please do not hesitate to call Peter Ramanauskas, of my staff, at (312) 886-7890.

Sincerely,

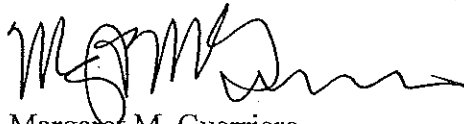
A handwritten signature in black ink, appearing to read 'M. Guerriero', with a stylized flourish at the end.

Margaret M. Guerriero
Director
Land and Chemicals Division

Enclosure

**ATTACHMENT 1: PCB RISK-BASED APPROVAL CONDITIONS
GE AVIATION – ALTITUDE TEST FACILITY**

GENERAL CONDITIONS

- 1) This Approval is granted under the authority of Section 6(e) of the Toxic Substances Control Act (TSCA), 15 U.S.C. §2605(e), and the Federal PCB Regulations at 40 CFR Part 761, and applies solely to the PCB Bulk Product Waste located at the site.
- 2) GE shall conduct on-site activities in accordance with the conditions of this Approval and the Submission.
- 3) In the event that the cleanup plan described in the Submission differs from the conditions specified in this Approval, the conditions of this Approval shall govern.
- 4) The terms and abbreviations used herein shall have the meanings as defined in 40 CFR §761.3 unless otherwise defined in this Approval.
- 5) All sampling and analysis conducted under this Approval will be performed in accordance with the EPA Region 5 RCRA Quality Assurance Project Plan Policy (April 1998) as appropriate for the site. EPA may audit laboratories selected by GE or require GE to purchase and have analyzed any Performance Evaluation (“PE”) samples selected by EPA.
- 6) GE must comply with all applicable federal, state, and local regulations in the storage, handling, and disposal of all PCB wastes, including PCBs, PCB Items, and decontamination wastes generated under this Approval.
- 7) GE is responsible for the actions of all officers, employees, agents, contractors, subcontractors, and others who are involved in activities conducted under this Approval. If at any time GE has or receives information indicating that GE has failed, or may have failed, to comply with any provision of this Approval, it must report the information to EPA in writing within 24 hours of having or receiving the information.
- 8) This Approval does not constitute a determination by EPA that the transporters or disposal facilities selected by GE are authorized to conduct the activities set forth in the Submission. GE is responsible for ensuring that its selected transporters and disposal facilities are authorized to conduct these activities in accordance with all applicable federal, state, and local statutes and regulations.
- 9) This approval does not: 1) waive or compromise EPA’s enforcement and regulatory authority; 2) release GE from compliance with any applicable requirements of federal, state, or local law; or 3) release GE from liability for, or otherwise resolve, any violations of federal, state, or local law.

INTERIM OPERATIONAL CONDITIONS

- 10) The interior of the inlet air induction piping network will be double washed, double rinsed and double painted, consistent with 40 CFR §761.30(p).
- 11) PCB M_L signs will be installed at appropriate locations, including entrance points to the ATF.

- 12) The exterior of the inlet air induction pipes are, with the exception of certain fittings and appurtenances, covered with a multi-layer protective barrier, completed with an aluminum sheathing. This covering will be maintained and the piping marked appropriately.
- 13) To ensure indoor air PCB concentrations remain protective for occupational exposures during the four engine tests, indoor air sampling shall be conducted during the interim action at locations outside of the control room but within the ATF where there is the potential for maximum exposure time for occupational workers. GE will notify EPA in writing of the location(s), rationales, and chosen methodology of the air sampling at the ATF during the interim action within 10 days of this Approval.
 - i) Indoor air sampling shall be conducted in accordance with EPA Method TO-4A or TO-10A. Sufficient sample volumes shall be collected to provide a minimum laboratory reporting limit of $< 0.05 \mu\text{g}/\text{m}^3$.
 - ii) Analytical results of air sampling shall be submitted to EPA within 5 business days of the GE's receipt of results.
- 14) To the maximum extent practical, engineering controls, such as barriers, and removal techniques, such as the use of HEPA ventilated tools, shall be used during any removal processes required during the interim operations. In addition, to the maximum extent possible, disposable equipment and materials, including PPE, will be used to reduce the amount of decontamination necessary.
- 15) Any paints removed from the inlet air induction system shall be disposed off-site as PCB Bulk Product Waste per 40 CFR §761.62.
- 16) PCB waste at any concentration generated as a result of the activities described in the Submission shall be marked in accordance with 40 CFR §761.40; stored in a manner consistent with 40 CFR §761.65; and disposed of in accordance with 40 CFR §761.61 or §761.62, unless otherwise specified below.
 - i) Decontamination wastes and residues shall be disposed of in accordance with 40 CFR § 761.79(g)(6).
 - ii) Movable equipment, tools, and sampling equipment shall be decontaminated in accordance with either 40 CFR §761.79(b)(3)(i)(A), §761.79(b)(3)(ii)(A), or §761.79(c)(2).
 - iii) PCB contaminated water generated during decontamination or dewatering shall be decontaminated in accordance with 40 CFR §761.79(b)(1) or disposed of under §761.60.

INSPECTION, MONITORING, MODIFICATION AND REVOCATION CONDITIONS

- 17) Within 45 days of the date of this Approval, GE shall submit for EPA's review and approval, a detailed work plan for the permanent removal of the PCB Bulk Product Waste paints on the inlet air induction system at the ATF.
- 18) GE shall allow any authorized representative of the Administrator of the EPA to inspect the site, inspect records, and take samples as may be necessary to determine compliance with the PCB

regulations and this Approval. Any refusal by GE to allow such an inspection (as authorized by Section 11 of TSCA) shall be grounds for revocation of this Approval.

- 19) Any proposed modification in the plan or specifications contained in the Submission or any departure from the conditions of this Approval without prior, written authorization from the EPA may result in revocation, suspension, and/or modification of the Approval, in addition to any other legal or equitable relief or remedy EPA may chose to pursue.
- 20) Any misrepresentation or omission of any material fact in the Submission or in any records or reports may result in EPA's revocation, suspension, and/or modification of the Approval, in addition to any other legal or equitable relief or remedy the EPA may chose to pursue.

RECORDKEEPING AND REPORTING CONDITIONS

- 21) GE shall prepare and maintain all records and documents required by 40 CFR Part 761, including, but not limited to, the records required under Subparts J and K in one centralized location. All records shall be made available for inspection to authorized representatives of EPA.
- 22) GE shall submit a Final Completion Report (Report) to EPA within 120 days of the completion of the activities described under the Submission and this Approval. At a minimum, this Report shall include: a discussion of the interim actions conducted, including any modifications that were made to the plan; indoor air sampling analytical results; copies of the accompanying analytical chains of custody; field and laboratory quality control/quality assurance checks; an estimate of any quantity of PCBs removed and disposed off-site; copies of manifests and/or bills of lading; and copies of certificates of disposal or similar certifications issued by the disposer, if applicable. The report shall also include a certification signed by a GE official verifying that the authorized activities have been implemented in accordance with this Approval and the Submission.

No record, report or communication required under this Approval shall qualify as a self-audit or voluntary disclosure under EPA audit, self-disclosure, or penalty policies.



Attachment C

Air Monitoring Plan

General Electric Company

**Indoor Ambient Air PCB
Monitoring Plan During
Engine Testing At The
Altitude Test Facility (ATF)**

GE Aviation, Evendale, Ohio

December 2013



**Indoor Ambient Air PCB
Monitoring Plan During
Engine Testing At The
Altitude Test Facility (ATF)**

Prepared for:
GE Aviation
Evendale, Ohio

Prepared by:
ARCADIS U.S., Inc.
6723 Towpath Road
P O Box 66
Syracuse
New York 13214-0066
Tel 315 446 9120
Fax 315 449 0017

Our Ref.:
B0031231.0000.00004

Date:
December 2013



1. Introduction	1
2. Sampling Objective	2
3. Indoor Ambient Air PCB Monitoring Program	3
3.1 Indoor Ambient Air PCB Sampling	3
3.2 Analytical Procedures	4
4. Quality Assurance and Quality Control Procedures	6
5. PCB Sampling Documentation, Handling, and Shipment	7
6. Reporting and Recordkeeping	8
7. Decision Criteria	9

Figure

Figure 1 PCB Air Monitoring Locations

Attachment

- A Determination of Pesticides and Polychlorinated Biphenyls in Ambient Air Using Low Volume Polyurethane Foam (PUF) Sampling Followed by Gas Chromatographic/Multi-Detector Detection (GC/MD)



1. Introduction

This Indoor Ambient Air PCB Monitoring Plan (Plan) has been developed by ARCADIS, U.S., Inc. to support indoor ambient air monitoring for polychlorinated biphenyls (PCBs) prior to, during, and following jet engine testing under the United States Environmental Protection Agency (USEPA) approval of December 19, 2012 (2012 Approval) to operate the Altitude Test Facility (ATF) at GE Aviation's facility in Evendale, Ohio (Facility). Air sampling previously was conducted during jet engine testing activities between January 2013 and July 31, 2013. Additional air sampling will be conducted before and during jet engine testing activities that re-commence in January 2014, following remediation of interior portions of and removal/replacement of air induction system piping. This air sampling will continue through December 31, 2014 when ATF remediation is completed.



2. Sampling Objective

The objectives of this Plan are to obtain representative data on ambient levels of PCBs within the ATF during jet engine testing, as described above.

3. Indoor Ambient Air PCB Monitoring Program

This plan utilizes USEPA Compendium Method TO-10A (Method TO-10A), an ambient PCB air monitoring procedure that is based on the absorption of PCBs from the ambient air on polyurethane foam (PUF) using a low volume sampler. Additional details regarding the monitoring program are provided below.

3.1 Indoor Ambient Air PCB Sampling

The sampling portion of the monitoring program will include the following elements:

Monitoring Locations	2
Sampling Time	8 hours per sampling event
Completed Sampling Period	January 2013 – July 2013
Planned Sampling Period	January 2014 – December 31, 2014
Frequency of Sampling	One sampling event in January 2014, prior to re-commencing jet engine testing. Three sampling events per jet engine test (described below).
Sampling Method	EPA Compendium Method TO-10A
Analytical Method	GC/MD as described in EPA Method TO-10A

The following sampling events will be performed during each of the engine test events conducted in 2014: 1) one sampling event during the test preparation period (i.e., pre-engine operation); 2) one sampling event during engine operation; and 3) one sampling event during the test shutdown period (i.e., following the completion of engine test) at the two air monitoring locations. For the sampling event to be performed during engine operation, the 8-hour sampling event will be selected early in the test cycle, as soon as the testing process reaches consistent operation up to 8-hour intervals. Depending on the type of engine test, it may not be feasible to conduct sampling during 8 hours of constant operation. In which case, monitoring will take place during a period as close to constant operation over 8 hours as possible.

Two ambient PCB monitoring locations (A and B) have been selected as presented on Figure 1. Monitoring location A is on the ground floor of the ATF, just outside of the engine test chamber (either chamber # 43 or # 44, at the location of the engine being tested). This is an area from which workers periodically may observe the jet engine testing process. Monitoring location B is on the second floor mezzanine level of the ATF, near the air compressors. This is an area from which workers periodically may monitor the operation of the compressors that are necessary to the jet engine testing process. These two monitoring locations represent areas outside of the control room, where workers may be present in the ATF for limited periods of time during engine testing activities.

This Plan utilizes USEPA Compendium Method TO-10A for the monitoring of ambient PCBs. A copy of the methodology (*Determination of Pesticides and Polychlorinated Biphenyls in Ambient Air Using Low Volume Polyurethane Foam (PUF) Sampling Followed by Gas Chromatographic/Multi-Detector Detection (GC/MD)*) has been included in Attachment A for reference purposes. This method employs a modified low volume sampler consisting of a glass fiber filter with a PUF backup absorbent cartridge to sample ambient air at a rate of 1 to 5 liters per minute (L/min). Upon completion of the 8-hour sample event, the filter and cartridge will be placed in a clean, sealed container and returned to the laboratory for analysis.

Procedures for sample media preparation and calibration of the sampling system are specified in Method TO-10A. In addition, Method TO-10A also specifies procedures for calculation and data reporting and the assessment of data for accuracy and precision.

Monitoring equipment will be inspected periodically during each 8-hour sampling event. At the end of the sampling event, the fiber filters and PUF adsorbents will be removed from the samplers. Each glass fiber filter will be folded and placed on the PUF adsorbent for that sample and each sample consisting of a fiber filter and PUF adsorbent (inside a glass cartridge) will be wrapped in hexane rinsed aluminum foil. Each fiber filter and PUF adsorbent set will be labeled as one sample. The samples will be wrapped, packaged in ice, and sent under chain-of-custody to the laboratory for analysis.

3.2 Analytical Procedures

Ambient PCB samples will be recovered and analyzed in accordance with procedures contained in Method TO-10A. The extracts will be analyzed for PCB using gas chromatography with either electron capture detection (GC/ECD) or mass spectrometry detection (GC/MS) as described in Method TO-10A. The samples will be analyzed for the following PCB Aroclors: PCB-1016, PCB-1221, PCB-1232, PCB-1242, PCB-1248, PCB-

**Indoor Ambient Air PCB
Monitoring Plan During
Engine Testing At The
Altitude Test Facility (ATF)**

1254, PCB-1260, PCB-1262, and PCB-1268. Samples typically will be subject to a standard turnaround time (TAT) of ten (10) business days.

For the laboratory analyses of ambient PCB samples, Pace Analytical, an independent laboratory has been selected based on the following factors:

- Experience analyzing air samples for PCBs
- Certification for air sample analysis
- Capacity of the laboratory to prepare and analyze the air samples required
- Laboratory Quality Assurance Plan that will meet this project's data quality requirements
- Written standard operating procedures for all of the laboratories operations
- Sample retention and disposal
- Laboratory report contents
- Well-documented, internal chain of custody system

4. Quality Assurance and Quality Control Procedures

Quality assurance and quality control (QA/QC) procedures for the PCB air sampling program follow those described in Method TO-10A. QA/QC for the particulate sampling will be based on manufacturer's recommendations.

In addition, the PCB analytical data received from the laboratory will be validated to compare the laboratory chemistry data against the criteria established for the data through an independent review. The data validation will be performed after the laboratory has completed quality control checks. Validation of the PCB data will determine whether the data is acceptable by evaluation the following items:

- Confirming the laboratory has provided the deliverables required by the contract, method of analysis, and/or the monitoring plan.
- Evaluating the laboratory performance based on the quality control summaries provided by the laboratory (e.g., holding times, calibration, blanks, precision).
- Checking for quantitative and qualitative error by reviewing the data transcripts of the sample and quality control data, evaluating the analyte identifications, and recalculating the quantification of analyte concentrations.

Following validation, qualifiers will be assigned to the data points affected by quality control outliers. The qualifiers indicated that the analyte concentrations: 1) may be affected by laboratory or field contamination, 2) is unusable because of quality control deficiencies, and/or 3) is estimated due to possible bias or reduced confidence in the results.



5. PCB Sampling Documentation, Handling, and Shipment

Each filter holder and PUF cartridge holder will be pre-marked with a permanent identification number. As each sample is collected, it will be recorded on a field data form along with the date, time, and location of collection.

All samples will be wrapped securely for shipment. PCB samples will be preserved at 4°C and shipped on ice. Samples will be shipped under chain-of-custody by commercial overnight carrier or courier to the analytical laboratory.



6. Reporting and Recordkeeping

PCB data results will be submitted to USEPA via letter report within five (5) business days from receipt by GE of the report from the laboratory. In addition, GE will maintain records associated with implementing this air monitoring plan until July 2015.



7. Decision Criteria

Indoor air sampling results will be reviewed against the National Institute for Occupational Safety and Health (NIOSH) Recommended Exposure Limit (REL) for PCBs of one microgram per cubic meter ($1.0 \mu\text{g}/\text{m}^3$) time-weighted average (TWA). Should any of the sampling results indicate total PCB concentrations in exceedance of the NIOSH REL for PCBs, GE will notify the USEPA in writing (e.g.: within 24 hours of receipt of the laboratory analytical results), and will evaluate worker safety protections including the need for respiratory protection and facility ventilation. In addition, GE will conduct follow-up sampling events, following the implementation of any needed worker safety protections, to demonstrate that ambient air PCB concentrations have been reduced below the NIOSH REL prior to scheduling any new jet engine tests.

Figure

CITY: SYRACUSE, NY DIV: GROUP: ENV/AD DB: LPOBENAUER LD: (00) PIC: (00) PK: C.AVERILL TR: (00) LY: (00) KW: OFF=PREP
 V: ENV/CA/OS/STRUC/E/ACT/03/03/10/00000001/DWG/03/12/15/00.dwg - LAYOUT: 1. SAVED: 14/2013 11:25 AM ACADVER: 18.15 (LMS TECH) PAGES: 18
 XREFS: 0: 12/15/13.dwg

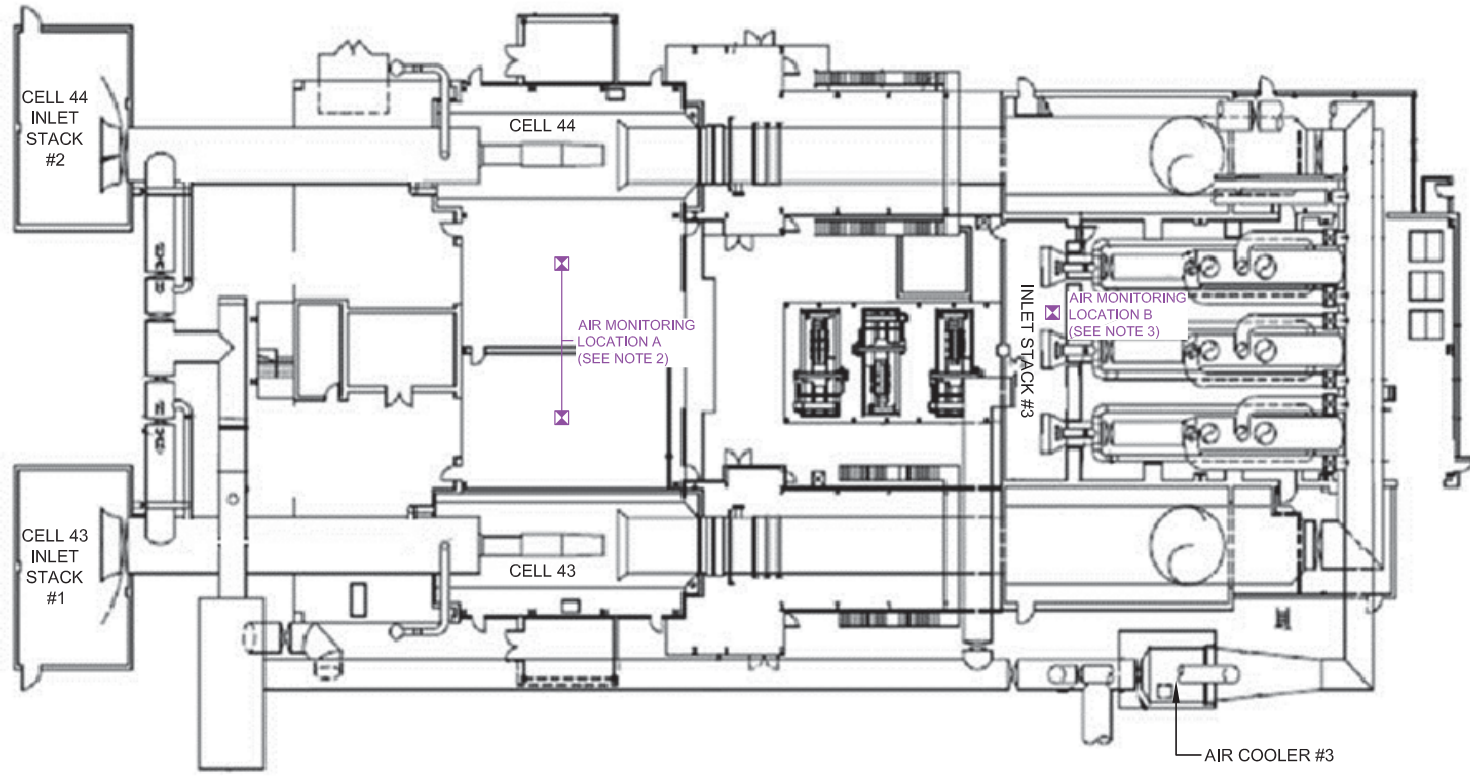

LEGEND:

✕ AMBIENT PCB AIR MONITORING LOCATION

NOTES:

1. SAMPLING LOCATIONS APPROXIMATE.
2. MONITORING LOCATION A IS ON THE GROUND FLOOR OF THE ATF, JUST OUTSIDE OF ENGINE TEST CHAMBER #43 OR #44, DEPENDING ON WHICH ENGINE IS BEING TESTED.
3. MONITORING LOCATION B IS ON THE SECOND FLOOR MEZZANINE LEVEL OF THE ATF, NEAR THE AIR COMPRESSORS.

NOT TO SCALE

GE-AVIATION CINCINNATI, OHIO	
AMBIENT PCB AIR MONITORING LOCATIONS	
	FIGURE 1



Attachment A

Determination of Pesticides and Polychlorinated Biphenyls in Ambient Air Using Low Volume Polyurethane Foam (PUF) Sampling Followed by Gas Chromatographic/Multi-Detector Detection (GC/MD)

**Compendium of Methods
for the Determination of
Toxic Organic Compounds
in Ambient Air**

Second Edition

Compendium Method TO-10A

**Determination Of Pesticides And
Polychlorinated Biphenyls In Ambient
Air Using Low Volume Polyurethane
Foam (PUF) Sampling Followed By
Gas Chromatographic/Multi-Detector
Detection (GC/MD)**

**Center for Environmental Research Information
Office of Research and Development
U.S. Environmental Protection Agency
Cincinnati, OH 45268**

January 1999

Method TO-10A Acknowledgements

This Method was prepared for publication in the *Compendium of Methods for the Determination of Toxic Organic Compounds in Ambient Air, Second Edition* (EPA/625/R-96/010b), which was prepared under Contract No. 68-C3-0315, WA No. 3-10, by Midwest Research Institute (MRI), as a subcontractor to Eastern Research Group, Inc. (ERG), and under the sponsorship of the U.S. Environmental Protection Agency (EPA). Justice A. Manning, John Burckle, and Scott R. Hedges, Center for Environmental Research Information (CERI), and Frank F. McElroy, National Exposure Research Laboratory (NERL), all in the EPA Office of Research and Development (ORD), were responsible for overseeing the preparation of this method. Additional support was provided by other members of the Compendia Workgroup, which include:

- John Burckle, U.S. EPA, ORD, Cincinnati, OH
- James L. Cheney, Corps of Engineers, Omaha, NB
- Michael Davis, U.S. EPA, Region 7, KC, KS
- Joseph B. Elkins Jr., U.S. EPA, OAQPS, RTP, NC
- Robert G. Lewis, U.S. EPA, NERL, RTP, NC
- Justice A. Manning, U.S. EPA, ORD, Cincinnati, OH
- William A. McClenny, U.S. EPA, NERL, RTP, NC
- Frank F. McElroy, U.S. EPA, NERL, RTP, NC
- Heidi Schultz, ERG, Lexington, MA
- William T. "Jerry" Winberry, Jr., EnviroTech Solutions, Cary, NC

Method TO-10 was originally published in March of 1989 as one of a series of peer reviewed methods in the second supplement to "*Compendium of Methods for the Determination of Toxic Organic Compounds in Ambient Air*," EPA 600/4-89-018. In an effort to keep these methods consistent with current technology, Method TO-10 has been revised and updated as Method TO-10A in this Compendium to incorporate new or improved sampling and analytical technologies. In addition, this method incorporates ASTM Method D 4861-94, *Standard Practice for Sampling and Analysis of Pesticides and Polychlorinated Biphenyls in Air*.

This Method is the result of the efforts of many individuals. Gratitude goes to each person involved in the preparation and review of this methodology.

Author(s)

- Robert G. Lewis, U.S. EPA, NERL, RTP, NC

Peer Reviewers

- William T. "Jerry" Winberry, Jr., EnviroTech Solutions, Cary, NC
- Irene D. DeGraff, Supelco, Bellefonte, PA
- Lauren Drees, U.S. EPA, NRMRL, Cincinnati, OH

Finally, recognition is given to Frances Beyer, Lynn Kaufman, Debbie Bond, Cathy Whitaker, and Kathy Johnson of Midwest Research Institute's Administrative Services staff whose dedication and persistence during the development of this manuscript has enabled it's production.

DISCLAIMER

This Compendium has been subjected to the Agency's peer and administrative review, and it has been approved for publication as an EPA document. Mention of trade names or commercial products does not constitute endorsement or recommendation for use.

METHOD TO-10A

Determination Of Pesticides And Polychlorinated Biphenyls In Ambient Air Using Low Volume Polyurethane Foam (PUF) Sampling Followed By Gas Chromatographic/Multi-Detector Detection (GC/MD)

TABLE OF CONTENTS

	<u>Page</u>
1. Scope	10A-1
2. Summary of Method	10A-1
3. Significance	10A-2
4. Applicable Documents	10A-2
4.1 ASTM Standards	10A-2
4.2 EPA Documents	10A-2
4.3 Other Documents	10A-3
5. Definitions	10A-3
6. Interferences	10A-3
7. Equipment and Materials	10A-4
7.1 Materials for Sample Collection	10A-4
7.2 Equipment for Analysis	10A-5
7.3 Reagents and Other Materials	10A-5
8. Assembly and Calibration of Sampling System	10A-6
8.1 Description of Sampling Apparatus	10A-6
8.2 Calibration of Sampling System	10A-6
9. Preparation of PUF Sampling Cartridges	10A-6
10. Sampling	10A-7
11. Sample Extraction Procedure	10A-8
11.1 Sample Extraction	10A-8
11.2 Sample Cleanup	10A-9

TABLE OF CONTENTS (continued)

	<u>Page</u>
12. Analytical Procedure	10A-10
12.1 Analysis of Organochlorine Pesticides by Capillary Gas Chromatography with Electron Capture Detector (GC/ECD)	10A-10
12.2 Analysis of Organophosphorus Pesticides by Capillary Gas Chromatography with Flame Photometric or Nitrogen-Phosphorus Detectors (GC/FPD/NPD)	10A-11
12.3 Analysis of Carbamate and Urea Pesticides by Capillary Gas Chromatography with Nitrogen-Phosphorus Detector	10A-11
12.4 Analysis of Carbamate, Urea, Pyrethroid, and Phenolic Pesticides by High Performance Liquid Chromatography (HPLC)	10A-11
12.5 Analysis of Pesticides and PCBs by Gas Chromatography with Mass Spectrometry Detection (GC/MS)	10A-12
12.6 Sample Concentration	10A-12
13. Calculations	10A-13
13.1 Determination of Concentration	10A-13
14. Sampling and Retention Efficiencies	10A-15
14.1 General	10A-15
14.2 Determining SE	10A-15
15. Performance Criteria and Quality Assurance	10A-17
15.1 Standard Operating Procedures (SOPs)	10A-17
15.2 Process, Field, and Solvent Blanks	10A-17
15.3 Sampling Efficiency and Spike Recovery	10A-17
15.4 Method Precision and Bias	10A-18
15.5 Method Safety	10A-18
16. References	10A-18

METHOD TO-10A

Determination Of Pesticides And Polychlorinated Biphenyls In Ambient Air Using Low Volume Polyurethane Foam (PUF) Sampling Followed By Gas Chromatographic/Multi-Detector (GC/MD) Detection

1. Scope

1.1 This document describes a method for sampling and analysis of a variety of common pesticides and for polychlorinated biphenyls (PCBs) in ambient air. The procedure is based on the adsorption of chemicals from ambient air on polyurethane foam (PUF) or a combination of PUF and granular sorbent using a low volume sampler.

1.2 The low volume PUF sampling procedure is applicable to multicomponent atmospheres containing common pesticide concentrations from 0.001 to 50 $\mu\text{g}/\text{m}^3$ over 4- to 24-hour sampling periods. The limits of detection will depend on the nature of the analyte and the length of the sampling period.

1.3 Specific compounds for which the method has been employed are listed in Table 1. The analytical methodology described in Compendium Method TO-10A is currently employed by laboratories throughout the U.S. The sampling methodology has been formulated to meet the needs of common pesticide and PCB sampling in ambient air.

1.4 Compendium Method TO-10 was originally published in 1989. The method was further modified for indoor air application in 1990. In an effort to keep the method consistent with current technology, Compendium Method TO-10 has incorporated ASTM Method D4861-94 (1) and is published here as Compendium Method TO-10A.

2. Summary of Method

2.1 A low-volume (1 to 5 L/minute) sample is used to collect vapors on a sorbent cartridge containing PUF or PUF in combination with another solid sorbent. Airborne particles may also be collected, but the sampling efficiency is not known (2).

2.2 Pesticides and other chemicals are extracted from the sorbent cartridge with 5 percent diethyl ether in hexane and determined by gas chromatography coupled with an electron capture detector (ECD), nitrogen-phosphorus detector (NPD), flame photometric detector (FPD), Hall electrolytic conductivity detector (HECD), or a mass spectrometer (MS). For common pesticides, high performance liquid chromatography (HPLC) coupled with an ultraviolet (UV) detector or electrochemical detector may be preferable. This method describes the use of an electron capture detector.

2.3 Interferences resulting from analytes having similar retention times during GC analysis are resolved by improving the resolution or separation, such as by changing the chromatographic column or operating parameters, or by fractionating the sample by column chromatography.

3. Significance

3.1 Pesticide usage and environmental distribution are common to rural and urban areas of the United States. The application of pesticides can cause potential adverse health effects to humans by contaminating soil, water, air, plants, and animal life. However, human exposure to PCBs continues to be a problem because of their presence in the environment.

3.2 Many pesticides and PCBs exhibit bioaccumulative, chronic health effects; therefore, monitoring the presence of these compounds in ambient air is of great importance.

3.3 Use of a portable, low volume PUF sampling system allows the user flexibility in locating the apparatus. The user can place the apparatus in a stationary or mobile location. The portable sampling apparatus may be positioned in a vertical or horizontal stationary location (if necessary, accompanied with supporting structure). Mobile positioning of the system can be accomplished by attaching the apparatus to a person to test air in the individual's breathing zone.

3.4 Moreover, this method has been successfully applied to measurement of common pesticides in outdoor air, indoor air and for personal respiratory exposure monitoring (3).

4. Applicable Documents

4.1 ASTM Standards

- D1356 *Definition of Terms Relating to Atmospheric Sampling and Analysis*
- D4861-94 *Standard Practice for Sampling and Analysis of Pesticides and Polychlorinated Biphenyls in Air*
- E260 *Recommended Practice for General Gas Chromatography Procedures*
- E355 *Practice for Gas Chromatography Terms and Relationships*
- D3686 *Practice for Sampling Atmospheres to Collect Organic Compound Vapors (Activated Charcoal Tube Adsorption Method)*
- D3687 *Practice for Analysis of Organic Compound Vapors Collected by the Activated Charcoal Tube Adsorption*
- D4185 *Practice for Measurement of Metals in Workplace Atmosphere by Atomic Absorption Spectrophotometry*

4.2 EPA Documents

- *Compendium of Methods for the Determination of Toxic Organic Compounds in Ambient Air: Method TO-10, Second Supplement*, U. S. Environmental Protection Agency, EPA 600/4-89-018, March 1989.
- *Manual of Analytical Methods for Determination of Pesticides in Humans and Environmental Standards*, U. S. Environmental Protection Agency, EPA 600/8-80-038, June 1980.
- *Compendium of Methods for the Determination of Air Pollutants in Indoor Air: Method IP-8*, U. S. Environmental Protection Agency, EPA 600/4-90-010, May 1990.

4.3 Other Documents

- Code of Federal Regulations, Title 40, Part 136, Method 604

5. Definitions

[Note: Definitions used in this document and in any user-prepared Standard operating procedures (SOPs) should be consistent with ASTM D1356, E260, and E355. All abbreviations and symbols are defined within this document at point of use.]

5.1 Sampling efficiency (SE)-ability of the sampling medium to trap analytes of interest. The percentage of the analyte of interest collected and retained by the sampling medium when it is introduced as a vapor in air or nitrogen into the air sampler and the sampler is operated under normal conditions for a period of time equal to or greater than that required for the intended use is indicated by %SE.

5.2 Retention efficiency (RE)-ability of sampling medium to retain a compound added (spiked) to it in liquid solution.

5.3 Static retention efficiency-ability of the sampling medium to retain the solution spike when the sample cartridge is stored under clean, quiescent conditions for the duration of the test period.

5.4 Dynamic retention efficiency (RE_d)-ability of the sampling medium to retain the solution spike when air or nitrogen is drawn through the sampling cartridge under normal operating conditions for the duration of the test period. The dynamic RE is normally equal to or less than the SE.

5.5 Retention time (RT)-time to elute a specific chemical from a chromatographic column, for a specific carrier gas flow rate, measured from the time the chemical is injected into the gas stream until it appears at the detector.

5.6 Relative retention time (RRT)-a ratio of RTs for two chemicals for the same chromatographic column and carrier gas flow rate, where the denominator represents a reference chemical.

5.7 Surrogate standard-a chemically inert compound (not expected to occur in the environmental sample) that is added to each sample, blank, and matrix-spiked sample before extraction and analysis. The recovery of the surrogate standard is used to monitor unusual matrix effects, gross sample processing errors, etc. Surrogate recovery is evaluated for acceptance by determining whether the measured concentration falls within acceptable limits.

6. Interferences

6.1 Any gas or liquid chromatographic separation of complex mixtures of organic chemicals is subject to serious interference problems due to coelution of two or more compounds. The use of capillary or microbore columns with superior resolution or two or more columns of different polarity will frequently eliminate these problems. In addition, selectivity may be further enhanced by use of a MS operated in the selected ion monitoring (SIM) mode as the GC detector. In this mode, co-eluting compounds can often be determined.

6.2 The ECD responds to a wide variety of organic compounds. It is likely that such compounds will be encountered as interferences during GC/ECD analysis. The NPD, FPD, and HECD detectors are element specific, but are still subject to interferences. UV detectors for HPLC are nearly universal, and the electrochemical detector may also respond to a variety of chemicals. Mass spectrometric analyses will generally provide positive identification of specific compounds.

6.3 PCBs and certain organochlorine pesticides (e.g., chlordane) are complex mixtures of individual compounds which can cause difficulty in accurately quantifying a particular formulation in a multiple component mixture. PCBs may interfere with the determination of pesticides.

6.4 Contamination of glassware and sampling apparatus with traces of pesticides or PCBs can be a major source of error, particularly at lower analyte concentrations. Careful attention to cleaning and handling procedures is required during all steps of sampling and analysis to minimize this source of error.

6.5 The general approaches listed below should be followed to minimize interferences.

6.5.1 Polar compounds, including certain pesticides (e.g., organophosphorus and carbamate classes) can be removed by column chromatography on alumina. Alumina clean-up will permit analysis of most organochlorine pesticides and PCBs (4).

6.5.2 PCBs may be separated from other organochlorine pesticides by column chromatography on silicic acid (5,6).

6.5.3 Many pesticides can be fractionated into groups by column chromatography on Florisil (6).

7. Equipment and Materials

7.1 Materials for Sample Collection

7.1.1 Continuous-Flow Sampling Pump (see Figure 1). The pump should provide a constant air flow ($\leq \pm 5\%$), be quiet and unobtrusive, with a flow rate of 1 to 5 L/min. Sources of equipment are Supelco, Supelco Park, Bellefonte, PA; SKC, 334 Valley View Road, Eighty Four, PA and other manufacturers.

7.1.2 Sampling Cartridge (see Figure 2). Constructed from a 20-mm (I.D.) x 10-cm borosilicate glass tube drawn down to a 7-mm (O.D.) open connection for attachment to the pump by way of flexible tubing (see Figure 1).

7.1.3 Sorbent, Polyurethane Foam (PUF). Cut into a cylinder, 22-mm I.D. and 7.6-cm long, fitted under slight compression inside the cartridge. The PUF should be of the polyether type, (density of 0.0225 g/cm³). This is the type of foam used for furniture upholstery, pillows, and mattresses. The PUF cylinders (plugs) should be slightly larger in diameter than the internal diameter of the cartridge. The PUF sorbent may be cut by one of the following means:

- With a high-speed cutting tool, such as a motorized cork borer. Distilled water should be used to lubricate the cutting tool.
- With a hot wire cutter. Care should be exercised to prevent thermal degradation of the foam.
- With scissors, while plugs are compressed between the 22-mm circular templates.

Alternatively, pre-extracted PUF plugs and glass cartridges may be obtained commercially.

7.1.4 Particle Filter. The collection efficiency of PUF for small-diameter (0.1 to 1 μm) airborne particles is only about 20% (7). However, most pesticides and PCBs exist in air under steady-state conditions primarily as vapors (8). Most particulate-associated pesticides or PCBs, if any, will also tend to be vaporized from filters after collection (9). Collocated sampling with and without a quartz-fiber pre-filter has yielded indistinguishable results for a broad spectrum of pesticides and PCBs found in indoor air (10).

7.1.4.1 An open-face filter may be attached to the sampling cartridge by means of a union for 1-in. (25.4-mm) tubing.

7.1.4.2 A 32-mm diameter quartz microfibre filter (e.g., Palifelex® type 2500 QAT-UP) is placed in the open end of the union and supported by means of a screen or perforated metal plate [e.g., a 304-stainless steel disk, 0.0312-in. (0.8-mm) thick with 1/16-in. (1.6-mm) diameter round perforations at 132 holes per in.² (20 holes/cm²), 41% open area.]. A 32-mm Viton® O-ring is placed between the filter and outer nut to effect a seal (see Figure 3). This filter holder is available from Supelco Park, Bellefonte, PA; SKC, 334 Forty Eight, PA; and other manufacturers.

7.1.5 Size-Selective Impactor Inlet. A size-selective impactor inlet with an average particle-size cut-point of 2.5 μm or 10 μm mean diameter at a sampling rate of 4 L/min may be used to exclude nonrespirable airborne particulate matter (11). This inlet, particle filter support, sampling cartridge holders are available commercially from Supelco, Supelco Park, Bellefonte, PA; SKC, 334 Forty Eight, PA and University Research Glassware (URG), Chapel Hill, NC.

7.1.6 Tenax-TA. 60/80 mesh, 2,6-diphenylphenylene oxide polymer. Commercially available from Supelco, Supelco Park, Bellefonte, PA and SKC, 334 Forty Eight, PA.

7.2 Equipment for Analysis

7.2.1 Gas Chromatograph (GC). The GC system should be equipped with appropriate detector(s) and either an isothermally controlled or temperature programmed heating oven. Improved detection limits may be obtained with a GC equipped with a cool on-column or splitless injector.

7.2.2 Gas Chromatographic Column. As an example, a 0.32 mm (I.D.) x 30 m DB-5, DB-17, DB-608, and DB-1701 are available. Other columns may also provide acceptable results.

7.2.3 HPLC Column. As an example, a 4.6-mm x 25-cm Zorbax SIL or μ Bondpak C-18. Other columns may also provide acceptable results.

7.2.4 Microsyringes. 5 μL volume or other appropriate sizes.

7.3 Reagents and Other Materials

7.3.1 Round Bottom Flasks. 500 mL, T 24/40 joints, best source.

7.3.2 Capacity Soxhlet Extractors. 300 mL, with reflux condensers, best source.

7.3.3 Kuderna-Danish Concentrator. 500 mL, with Snyder columns, best source.

7.3.4 Graduated Concentrator Tubes. 10 mL, with 19/22 stoppers, best source.

7.3.5 Graduated Concentrator Tubes. 1 mL, with 14/20 stoppers, best source.

7.3.6 TFE Fluorocarbon Tape. 1/2 in., best source.

7.3.7 Filter Tubes. Size 40 mm (I.D.) x 80 mm.

7.3.8 Serum Vials. 1 mL and 5 mL, fitted with caps lined with TFE fluorocarbon.

7.3.9 Pasteur Pipettes. 9 in., best source.

7.3.10 Glass Wool. Fired at 500°C, best source.

7.3.11 Boiling Chips. Fired at 500°C, best source..

7.3.12 Forceps. Stainless steel, 12 in., best source.

7.3.13 Gloves. Latex or precleaned (5% ether/hexane Soxhlet extracted) cotton.

- 7.3.14 Steam Bath.**
- 7.3.15 Heating Mantles.** 500 mL.
- 7.3.16 Analytical Evaporator.** Nitrogen blow-down.
- 7.3.17 Acetone.** Pesticide quality.
- 7.3.18 n-Hexane.** Pesticide quality.
- 7.3.19 Diethyl Ether.** Preserved with 2% ethanol.
- 7.3.20 Sodium Sulfate.** Anhydrous analytical grade.
- 7.3.21 Alumina.** Activity Grade IV, 100/200 mesh.
- 7.3.22 Glass Chromatographic Column.** 2-mm I.D. x 15-cm long.
- 7.3.23 Soxhlet Extraction System.** Including Soxhlet extractors (500 and 300 mL), variable voltage transformers, and cooling water source.
- 7.3.24 Vacuum Oven.** Connected to water aspirator.
- 7.3.25 Die.**
- 7.3.26 Ice Chest.**
- 7.3.27 Silicic Acid.** Pesticide grade.
- 7.3.28 Octachloronaphthalene (OCN).** Research grade.
- 7.3.29 Florisil.** Pesticide grade.

8. Assembly and Calibration of Sampling System

8.1 Description of Sampling Apparatus

8.1.1 A typical sampling arrangement utilizing a personal air pump is shown in Figure 1. This method is designed to use air sampling pumps capable of pulling air through the sampling cartridge at flow rates of 1 to 5 L/min. The method writeup presents the use of this device.

8.1.2 The sampling cartridge (see Figure 2) consists of a glass sampling cartridge in which the PUF plug or PUF/Tenax® TA "sandwich" is retained.

8.2 Calibration of Sampling System

8.2.1 Air flow through the sampling system is calibrated by the assembly shown in Figure 4. All air sampler must be calibrated in the laboratory before and after each sample collection period, using the procedure described below.

8.2.2 For accurate calibration, attach the sampling cartridge in-line during calibration. Vinyl bubble tubing or other means (e.g., rubber stopper or glass joint) may be used to connect the large end of the cartridge to the calibration system. Refer to ASTM Practice D3686 or D4185, for procedures to calibrate small volume air pumps.

9. Preparation of PUF Sampling Cartridges

9.1 The PUF adsorbent is white and yellows upon exposure to light. The "yellowing" of PUF will not affect its ability to collect pesticides or PCBs.

9.2 For initial cleanup and quality assurance purposes, the PUF plug is placed in a Soxhlet extractor and extracted with acetone for 14 to 24 hours at 4 to 6 cycles per hour.

[Note: If commercially pre-extracted PUF plugs are used, extraction with acetone is not required.]

Follow with a 16-hour Soxhlet extraction with 5% diethyl ether in n-hexane. When cartridges are reused, 5% diethyl ether in n-hexane can be used as the cleanup solvent.

9.3 Place the extracted PUF in a vacuum oven connected to a water aspirator and dry at room temperature for 2 to 4 hours (until no solvent odor is detected). Alternatively, they may be dried at room temperature in an air-tight container with circulating nitrogen (zero grade). Place the clean PUF plug into a labeled glass sampling cartridges using gloves and forceps. Wrap the cartridges with hexane-rinsed aluminum foil and placed in jars fitted with TFE fluorocarbon-lined caps. The foil wrapping may also be marked for identification using a blunt probe.

9.4 Granular sorbents may be combined with PUF to extend the range of use to compounds with saturation vapor pressures greater than 10^{-4} kPa (6). A useful combination trap can be assembled by "sandwiching" 0.6 g of Tenax-TA between two 22-mm I.D. x 3.8-cm pre-cleaned PUF plugs, as shown in Figure 2, Cartridge b. The Tenax-TA should be pre-extracted as described in Section 9.2. This trap may be extracted, vacuum dried, and removed without unloading it.

9.5 Analyze at least one assembled cartridge from each batch as a laboratory blank before the batch is acceptable. A blank level of <10 ng/plug for single component compounds is considered to be acceptable. For multiple component mixtures (e.g., PCBs), the blank level should be <100 ng/plug.

9.6 After cleaning, cartridges are considered clean up to 30 days when stored in sealed containers. Certified clean cartridges do not need to be chilled when shipping to the field.

10. Sampling

[Note: After the sampling system has been assembled and calibrated as per Section 8, it can be used to collect air samples as described below. The prepared sample cartridges should be used within 30 days of certification and should be handled only with latex or precleaned cotton gloves.]

10.1 Carefully remove the clean sample cartridge from the aluminum foil wrapping (the foil is returned to jars for later use) and attached to the pump with flexible tubing. The sampling assembly is positioned with the intake downward or in horizontal position. Locate the sampler in an unobstructed area at least 30 meters from any obstacle to air flow. The PUF or PUF/XAD-2 cartridge intake is positioned 1 to 2 m above ground level. Cartridge height above ground is recorded on the Compendium Method TO-10A field test data sheet (FTDS), as illustrated in Figure 5.

10.2 After the PUF cartridge is correctly inserted and positioned, the power switch is turned on and the sampling begins. The elapsed time meter is activated and the start time is recorded. The pumps are checked during the sampling process and any abnormal conditions discovered are recorded on the FTDS. Ambient temperatures and barometric pressures are measured and recorded periodically during the sampling procedure on the FTDS.

10.3 At the end of the desired sampling period, the power is turned off, the PUF cartridge removed from the sampler and wrapped with the original aluminum foil and placed in a sealed, labeled container for transport, under blue ice (<4°C), back to the laboratory. At least one field blank is returned to the laboratory with each group of

samples. A field blank is treated exactly like a sample except that no air is drawn through the cartridge. Samples are stored at <4°C or below until analyzed in the laboratory. Extraction must occur within 7 days of sampling and analysis within 40 days of extraction. Refer to ASTM D4861-94 (1), Appendix X3 for storage stability for various common pesticides and other compounds on PUF or PUF/Tenax TA sandwich.

11. Sample Extraction Procedure

[Note: Sample extraction should be performed under a properly ventilated hood.]

11.1 Sample Extraction

11.1.1 All samples should be extracted within 1 week after collection. All samples should be stored at <4°C until extracted.

11.1.2 All glassware should be washed with a suitable detergent; rinsed with deionized water, acetone, and hexane; rinsed again with deionized water; and fired in an oven (500°C).

11.1.3 Prepare a spiking solution for determination of extraction efficiency. The spiking solution should contain one or more surrogate compounds that have chemical structures and properties similar to those of the analytes of interest. Octachloronaphthalene (OCN) and dibutylchlorendate have been used as surrogates for determination of organochlorine pesticides by GC with an ECD. Tetrachloro-m-xylene and decachlorobiphenyl can also be used together to insure recovery of early and late eluting compounds. For organophosphate pesticides, tributylphosphate or triphenylphosphate may be employed as surrogates. The surrogate solution should be prepared so that addition of 100 µL into the PUF plug results in an extract containing the surrogate compound at the high end of the instrument's calibration range. As an example, the spiking solution for OCN is prepared by dissolving 10 mg of OCN in 10 mL of 10% acetone in n-hexane, followed by serial dilution n-hexane to achieve a final spiking solution of OCN of 1 µg/mL.

[Note: Use the recoveries of the surrogate compounds to monitor for unusual matrix effects and gross sample processing errors. Evaluate surrogate recovery for acceptance by determining whether the measured concentration falls within the acceptance limits of 60-120 percent.]

11.1.4 The extracting solution (5% diethyl ether/hexane) is prepared by mixing 1900 mL of freshly opened hexane and 100 mL of freshly opened diethyl ether (preserved with ethanol) to a flask.

11.1.5 All clean glassware, forceps, and other equipment to be used should be rinsed with 5% diethyl ether/hexane and placed on rinsed (5% diethyl ether/hexane) aluminum foil until use. The condensing towers should also be rinsed with 5% diethyl ether/hexane. Then add 300 mL or 5% diethyl ether/hexane to the 500 mL round bottom boiling flask and add up to three boiling granules.

11.1.6 Using precleaned (i.e., 5% diethyl ether/hexane Soxhlet extracted) cotton gloves, the glass PUF cartridges are removed from the sealed container, the PUF removed from the glass container and is placed into the 300 mL Soxhlet extractor using prerinsed forceps.

[Note: If "sandwich" trap is used, carefully clean outside walls of cartridge with hexane-soaked cotton swabs or laboratory tissues (discard) and place cartridge into extractor with intake (large end) downward.]

11.1.7 Before extraction begins, add 100 µL of the OCN solution directly to the top of the PUF plug.

[Note: Incorporating a known concentration of the solution onto the sample provides a quality assurance check to determine recovery efficiency of the extraction and analytical processes.]

11.1.8 Connect the Soxhlet extractor to the 500 mL boiling flask and condenser. Wet the glass joints with 5% diethyl ether/hexane to ensure a tight seal between the fittings. If necessary, the PUF plug can be adjusted using forceps to wedge it midway along the length of the siphon. The above procedure should be followed for all samples, with the inclusion of a blank control sample.

11.1.9 The water flow to the condenser towers of the Soxhlet extraction assembly should be checked and the heating unit turned on. As the samples boil, the Soxhlet extractors should be inspected to ensure that they are filling and siphoning properly (4 to 6 cycles/hour). Samples should cycle for a minimum of 16 hours.

11.1.10 At the end of the extracting process (minimum of 16 hours), the heating unit is turned off and the sample cooled to room temperature.

11.1.11 The extracts are then concentrated to 5 mL using a Kuderna-Danish (K-D) apparatus. The K-D is set up, assembled with concentrator tubes, and rinsed. The lower end of the filter tube is packed with glass wool and filled with sodium sulfate to a depth of 40 mm. The filter tube is then placed in the neck of the K-D. The Soxhlet extractors and boiling flasks are carefully removed from the condenser towers and the remaining solvent is drained into each boiling flask. Sample extract is carefully poured through the filter tube into the K-D. Each boiling flask is rinsed three times by swirling hexane along the sides. Once the sample has drained, the filter tube is rinsed down with hexane. Each Snyder column is attached to the K-D and rinsed to wet the joint for a tight seal. The complete K-D apparatus is placed on a steam bath and the sample is evaporated to approximately 5 mL.

[Note: Do not allow samples to evaporate to dryness.]

Remove sample from the steam bath, rinse Snyder column with minimum of hexane, and allow to cool. Adjust sample volume to 10 mL in a concentrator tube, close with glass stopper and seal with TFE fluorocarbon tape. Alternatively, the sample may be quantitatively transferred (with concentrator tube rinsing) to prescored vials and brought up to final volume. Concentrated extracts are stored at <4°C until analyzed. Analysis should occur no later than 40 days after sample extraction.

11.2 Sample Cleanup

11.2.1 If polar compounds (from example, organophosphorus and carbamate classes) that interfere with GC/ECD analysis are present, use column chromatographic cleanup or alumina. The sample cleanup will permit the analysis of most organochlorine pesticides or PCBs.

11.2.2 Before cleanup, the sample extract is carefully reduced to 1 mL using a gentle stream of clean nitrogen.

11.2.3 A glass chromatographic column (2-mm I.D. x 15-cm long) is packed with alumina, activity grade IV, and rinsed with approximately 20 mL of n-hexane. The concentrated sample extract is placed on the column and eluted with 10 mL of n-hexane at a rate of 0.5 mL/minute. The eluate volume is adjusted to exactly 10 mL and analyzed as per Section 12.

11.2.4 If both PCBs and organochlorine pesticides are sought, alternate cleanup procedures (5,6) may be required (i.e., silicic acid).

11.2.5 Finally, class separation and improved specificity can be achieved by column clean-up and separation on Florisil (6).

12. Analytical Procedure

12.1 Analysis of Organochlorine Pesticides by Capillary Gas Chromatography with Electron Capture Detector (GC/ECD)

[Note: Organochlorine pesticides, PCBs and many nonchlorinated pesticides are responsive to electron capture detection (see Table 1). Most of these compounds can be analyzed at concentration of 1 to 50 ng/mL by GC/ECD. The following procedure is appropriate. Analytical methods that have been used to determine pesticides and PCBs collected from air by this procedure have been published (12).]

12.1.1 Select GC column (e.g., 0.3-mm by 30-m DB-5 column) and appropriate GC conditions to separate the target analytes. Typical operating parameters for this column with splitless injection are: Carrier gas-chromatography grade helium at a flow rate of 1 to 2 mL/min and a column head pressure of 7 to 9 psi (48 to 60 kPa); injector temperature of 250°C; detector temperature of 350°C; initial oven temperature of 50°C held for 2.0 min., ramped at 15°C/min to 150°C for 8 min, ramped at 10°C/min to 295°C then held for 5 min; purge time of 1.0 min. A typical injection volume is 2 to 3 μ L.

12.1.2 Remove sample extract from the refrigerator and allow to warm to room temperature.

12.1.3 Prepare standard solution from reference materials of known purity. Analytically pure standards of organochlorine pesticides and PCBs are available from several commercial sources.

12.1.4 Use the standard solutions of the various compounds of interest to determine relative retention times (RRTs) to an internal standard such as p,p'-DDE, aldrin or octachloronaphthalene. Use 1 to 3- μ L injections or other appropriate volumes.

12.1.5 Determine detector linearity by injecting standard solutions of three different concentrations (amounts) that bracket the range of analyses. The calibration is considered linear if the relative standard deviation (RSD) of the response factors for the three standards is 20 percent or less.

12.1.6 Calibrate the system with a minimum of three levels of calibration standards in the linear range. The low standard should be near the analytical method detection limit. The calibration is considered linear if the relative standard deviation (RSD) of the response factors for the three standards is 20 percent or less. The initial calibration should be verified by the analysis of a standard from an independent source. Recovery of 85 to 115 percent is acceptable. The initial calibration curve should be verified at the beginning of each day and after every ten samples by the analysis of the mid point standard; an RPD of 15% or less is acceptable for continuing use of the initial calibration curve.

12.1.7 Inject 1 to 3 μ L of the sample extract. Record volume injected to the nearest 0.05 μ L.

12.1.8 A typical ECD response for a mixture of single component pesticides using a capillary column is illustrated in Figure 6. If the response (peak height or area) exceeds the calibration range, dilute the extract and reanalyze.

12.1.9 Quantify PCB mixtures by comparison of the total heights or areas of GC peaks (minimum of 5) with the corresponding peaks in the best-matching standard. Use Aroclor 1242 for early-eluting PCBs and either Aroclor 1254 or Aroclor 1260 as appropriate for late-eluting PCBs.

12.1.10 If both PCBs and organochlorine pesticides are present in the same sample, use column chromatographic separation on silicic acid (5,6) prior to GC analysis.

12.1.11 If polar compounds are present that interfere with GC/ECD analysis, use column chromatographic cleanup or alumina, activity grade IV, in accordance with Section 11.2.

12.1.12 For confirmation use a second GC column such as DB-608. All GC procedures except GC/MS require second column confirmation.

12.1.13 For improved resolution use a capillary column such as an 0.25-mm I.D. x 30-m DB-5 with 0.25 μm film thickness. The following conditions are appropriate.

- Helium carrier gas at 1 mL/min.
- Column temperature program, 90°C (4 min)/16°C/min to 154°C/4°C/min to 270°C.
- Detector, ^{63}Ni ECD at 350°C.
- Make up gas, nitrogen, or 5% methane/95% argon at 60 mL/min.
- Splitless injection, 2 μL maximum.
- Injector temperature, 220°C.

12.1.14 Class separation and improved specificity can be achieved by column chromatographic separation on Florisil (6).

12.2 Analysis of Organophosphorus Pesticides by Capillary Gas Chromatography with Flame Photometric or Nitrogen-Phosphorus Detectors (GC/FPD/NPD)

[Note: Organophosphorus pesticides are responsive to flame photometric and nitrogen-phosphorus (alkali flame ionization) detection. Most of these compounds can be analyzed at concentrations of 50 to 500 ng/mL using either of these detectors.]

12.2.1 Procedures given in Section 12.1.1 through 12.1.9 and Section 12.1.13 through 12.1.14 apply, except for the selection of surrogates.

12.2.2 Use tributylphosphate, triphenylphosphate, or other suitable compound(s) as surrogates to verify extraction efficiency and to determine RRTs.

12.3 Analysis of Carbamate and Urea Pesticides by Capillary Gas Chromatography with Nitrogen-Phosphorus Detector

12.3.1 Trazine, carbamate, and urea pesticides may be determined by capillary GC (DB-5, DB-17, or DB-1701 stationary phase) using nitrogen-phosphorus detection or MS-SIM with detection limits in the 0.05 to 0.2 $\mu\text{L}/\text{mL}$ range. Procedures given in Section 12.1.1 through 12.1.9 and Section 12.1.13 through 12.1.14 apply, except for the selection of surrogates, detector, and make up gas.

12.3.2 Thermal degradation may be minimized by reducing the injector temperature to 200°C. HPLC may also be used, but detection limits will be higher (1 to 5 $\mu\text{g}/\text{mL}$).

12.3.3 N-methyl carbamates may be determined using reverse-phase high performance liquid chromatography (HPLC) (C-18) (Section 12.4) and post-column derivatization with o-phthaldehyde and fluorescence detection (EPA Method 531). Detection limits of 0.01 to 0.1 $\mu\text{g}/\text{mL}$ can be achieved.

12.4 Analysis of Carbamate, Urea, Pyrethroid, and Phenolic Pesticides by High Performance Liquid Chromatography (HPLC)

[Note: Many carbamate pesticides, urea pesticides, pyrethrins, phenols, and other polar pesticides may be analyzed by high HPLC with fixed or variable wavelength UV detection. Either reversed-phase or normal phase chromatography may be used. Detection limits are 0.2 to 10 $\mu\text{g}/\text{mL}$ of extract.]

12.4.1 Select HPLC column (i.e., Zorbax-SIL, 46-mm I.D. x 25-cm, or μ -Bondapak C18, 3.9-mm x 30-cm, or equivalent).

12.4.2 Select solvent system (i.e., mixtures of methanol or acetonitrile with water or mixtures of heptane or hexane with isopropanol).

12.4.3 Follow analytical procedures given in Sections 12.1.2 through 12.1.9.

12.4.4 If interferences are present, adjust the HPLC solvent system composition or use column chromatographic clean-up with silica gel, alumina, or Florisil (6).

12.4.5 An electrochemical detector may be used to improve sensitivity for some ureas, carbamates, and phenolics. Much more care is required in using this detector, particularly in removing dissolved oxygen from the mobile phase and sample extracts.

12.4.6 Chlorophenol (di- through penta-) may be analyzed by GC/ECD or GC/MS after derivatization with pentafluorobenzylbromide (EPA Method 604).

12.4.7 Chlorinated phenoxyacetic acid herbicides and pentachlorophenol can be analyzed by GC/ECD or GC/MS after derivatization with diazomethane (EPA Method 515). DB-5 and DB-1701 columns (0.25-mm I.D. x 30-m) at 60 to 300°C/4°C per min have been found to perform well.

12.5 Analysis of Pesticides and PCBs by Gas Chromatography with Mass Spectrometry Detection (GC/MS)

[Note: A mass spectrometer operating in the selected ion monitoring mode is useful for confirmation and identification of pesticides.]

12.5.1 A mass spectrometer operating in the select ion monitoring (SIM) mode can be used as a sensitive detector for multi-residue determination of a wide variety of pesticides. Mass spectrometers are now available that provide detection limits comparable to nitrogen-phosphorus and electron capture detectors.

12.5.2 Most of the pesticides shown in Table 1 have been successfully determined by GC/MS/SIM. Typical GC operating parameters are as described in Section 12.1.1.

12.5.3 The mass spectrometer is typically operated using positive ion electron impact ionization (70 eV). Other instrumental parameters are instrument specific.

12.5.4 p-Terphenyl-d₁₄ is commonly used as a surrogate for GC/MS analysis.

12.5.5 Quantification is typically performed using an internal standard method. 1,4-Dichlorobenzene, naphthalene-d₈, acenaphthene-d₁₀, phenanthrene-d₁₀, chrysene-d₁₂ and perylene-d₁₂ are commonly used as internal standards. Procedures given in Section 12.1.1 through 12.1.9 and Section 12.1.13 through 12.1.14 apply, except for the selection of surrogates, detector, and make up gas.

12.5.6 See ASTM Practice D 3687 for injection technique, determination of relative retention times, and other procedures pertinent to GC and HPLC analyses.

12.6 Sample Concentration

12.6.1 If concentrations are too low to detect by the analytical procedure of choice, the extract may be concentrated to 1 mL or 0.5 mL by carefully controlled evaporation under an inert atmosphere. The following procedure is appropriate.

12.6.2 Place K-D concentrator tube in a water bath and analytical evaporator (nitrogen blow-down) apparatus. The water bath temperature should be from 25°C to 50°C.

12.6.3 Adjust nitrogen flow through hypodermic needle to provide a gentle stream.

12.6.4 Carefully lower hypodermic needle into the concentrator tube to a distance of about 1 cm above the liquid level.

12.6.5 Continue to adjust needle placement as liquid level decreases.

12.6.6 Reduce volume to slightly below desired level.

12.6.7 Adjust to final volume by carefully rinsing needle tip and concentrator tube well with solvent (usually n-hexane).

13. Calculations

13.1 Determination of Concentration

13.1.1 The concentration of the analyte in the extract solution can be taken from a standard curve where peak height or area is plotted linearly against concentration in nanograms per milliliter (ng/mL). If the detector response is known to be linear, a single point is used as a calculation constant.

13.1.2 From the standard curve, determine the nanograms of analyte standard equivalent to the peak height or area for a particular compound.

13.1.3 Ascertain whether the field blank is contaminated. Blank levels should not exceed 10 ng/sample for organochlorine pesticides or 100 ng/sample for PCBs and other pesticides. If the blank has been contaminated, the sampling series must be held suspect.

13.1.4 Quantity of the compound in the sample (A) is calculated using the following equation:

$$A = 1000 \left(\frac{A_s \times V_e}{V_i} \right)$$

where:

A = total amount of analyte in the sample, ng.

A_s = calculated amount of material injected onto the chromatograph based on calibration curve for injected standards, ng.

V_e = final volume of extract, mL.

V_i = volume of extract injected, μL.

1000 = factor for converting microliters to milliliters.

13.1.5 The extraction efficiency (EE) is determined from the recovery of surrogate spike as follows:

$$EE(\%) = \left| \frac{S}{S_a} \right| [100]$$

where:

EE = extraction efficiency, %.

S = amount of spike recovered, ng.

S_a = amount of spike added to plug, ng.

The extraction efficiency (surrogate recovery) must fall between 60-120% to be acceptable.

13.1.6 The total volume of air sampled under ambient conditions is determined using the following equation:

$$V_a = \frac{\sum_{i=1}^n (T_i \times F_i)}{1000 \text{ L/m}^3}$$

where:

V_a = total volume of air sampled, m^3 .

T_i = length of sampling segment between flow checks, min.

F_i = average flow during sampling segment, L/min.

13.1.7 The air volume is corrected to EPA standard temperature (25°C) and standard pressure (760 mm Hg) as follows:

$$V_s = V_a \left(\frac{P_b - P_w}{760 \text{ mm Hg}} \right) \left(\frac{298\text{K}}{t_A} \right)$$

where:

V_s = volume of air at standard conditions (25°C and 760 mm Hg), std. m^3 .

V_a = total volume of air sampled, m^3 .

P_b = average ambient barometric pressure, mm Hg.

P_w = vapor pressure of water at calibration temperature, mm Hg.

t_A = average ambient temperature, $^\circ\text{C} + 273$.

13.1.8 If the proper criteria for a sample have been met, concentration of the compound in a standard cubic meter of air sampled is calculated as follows:

$$C_a(\text{ng/std. m}^3) = \left[\frac{(A)}{(V_s)} \right] \left[\frac{(100)}{(SE(\%))} \right]$$

where:

SE = sampling efficiency as determined by the procedure outlined in Section 14.

If it is desired to convert the air concentration value to parts per trillion (ppt) in dry air at standard temperature and pressure (STP), the following conversion is used:

$$\text{ppt} = 0.844 (C_a)$$

The air concentration can be converted to parts per trillion (v/v) in air at STP as follows:

$$\text{pptv} = \left[\frac{(24.45) (C_a)}{(MW)} \right]$$

where:

MW = molecular weight of the compound of interest, g/g-mole.

13.1.9 If quantification is performed using an internal standard, a relative response factor (RRF) is calculated by the equation:

$$\text{RRF} = \left[\frac{(I_s)(C_{is})}{(I_{is})(C_s)} \right]$$

where:

I_s = integrated area of the target analyte peak, counts.

I_{is} = integrated area of the internal standard peak, counts.

C_{is} = concentration of the internal standard, ng/ μ L.

C_s = concentration of the analyte, ng/ μ L.

13.1.10 The concentration of the analyte (C_a) in the sample is then calculated as follows:

$$C_a = \frac{(I_s)(C_{is})}{(\text{RRF})(I_{is})}$$

where:

C_a = concentration of analyte, ng/m³

I_s = integrated area of the target analyte peak, counts.

RRF = relative response factor (see Section 13.1.10).

14. Sampling and Retention Efficiencies

14.1 General

14.1.1 Before using Compendium Method TO-10A, the user should determine the sampling efficiency for the compound of interest. The sampling efficiencies shown in Tables 2, 3, 4, and 5 were determined for approximately 1 m³ of air at about 25°C, sampled at 3.8 L/min. The SE values in these tables may be used for similar sampling conditions; for other compounds or conditions, SE values must be determined.

14.1.2 Sampling efficiencies for the pesticides shown in Table 6 are for a flowrate of 3.8 L/min and at 25°C. For compounds not listed, longer sampling times, different flow rates, or other air temperatures, the following procedure may be used to determine sampling efficiencies.

14.2 Determining SE

14.2.1 SE is determined by a modified impinger assembly attached to the sampler pump, as illustrated in Figure 7. A clean PUF is placed in the pre-filter location and the inlet is attached to a nitrogen line.

[Note: Nitrogen should be used instead of air to prevent oxidation of the compounds under test. The oxidation would not necessarily reflect what may be encountered during actual sampling and may give misleading sampling efficiencies.]

Two PUF plugs (22-mm x 7.6-cm) are placed in the primary and secondary traps and are attached to the pump.

14.2.2 A standard solution of the compound of interest is prepared in a volatile solvent (i.e., hexane, pentane, or benzene). A small, accurately measured volume (i.e., 1 mL) of the standard solution is placed into the modified midget impinger. The sampler pump is set at the rate to be used in field application and then activated. Nitrogen is drawn through the assembly for a period of time equal to or exceeding that intended for field application. After the desired sampling test period, the PUF plugs are removed and analyzed separately as per Section 12.

14.2.3 The impinger is rinsed with hexane or another suitable solvent and quantitatively transferred to a volumetric flask or concentrator tube for analysis.

14.2.4 The sampling efficiency (SE) is determined using the following equation:

$$\% \text{ SE} = \frac{W_1}{W_0 - W_r} \times 100$$

where:

W_1 = amount of compound extracted from the primary trap, ng.

W_0 = original amount of compound added to the impinger, ng.

W_r = residue left in the impinger at the end of the test, ng.

14.2.5 If material is found in the secondary trap, it is an indication that breakthrough has occurred. The addition of the amount found in the secondary trap, W_2 , to W_1 , will provide an indication for the overall sampling efficiency of a tandem-trap sampling system. The sum of W_1 , W_2 (if any), and W_r must equal (approximately $\pm 10\%$) W_0 or the test is invalid.

14.2.6 If the compound of interest is not sufficiently volatile to vaporize at room temperature, the impinger may be heated in a water bath or other suitable heater to a maximum of 50°C to aid volatilization. If the compound of interest cannot be vaporized at 50°C without thermal degradation, dynamic retention efficiency (RE_d) may be used to estimate sampling efficiency. Dynamic retention efficiency is determined in the manner described in Section 14.2.7. Table 7 lists those organochlorine pesticides which dynamic retention efficiencies have been determined.

14.2.7 A pair of PUF plugs is spiked by slow, dropwise addition of the standard solution to one end of each plug. No more than 0.5 to 1 mL of solution should be used. Amounts added to each plug should be as nearly the same as possible. The plugs are allowed to dry for 2 hours in a clean, protected place (i.e., desiccator). One spiked plug is placed in the primary trap so that the spiked end is at the intake and one clean unspiked plug is placed in the secondary trap. The other spiked plug is wrapped in hexane-rinsed aluminum foil and stored in a clean place for the duration of the test (this is the static control plug, Section 14.2.8). Prefiltered nitrogen or ambient air is drawn through the assembly as per Section 14.2.2.

[Note: Impinger may be discarded.]

Each PUF plug (spiked and static control) is analyzed separately as per Section 12.

14.2.8 This dynamic retention efficiency ($\% RE_d$) is calculated as follows:

$$\% RE_d = \frac{W_1}{W_0} \times 100$$

where:

W_1 = amount of compound recovered from primary plug, ng.

W_o = amount of compound added to primary plug, ng.

If a residue, W_2 , is found on the secondary plug, breakthrough has occurred. The sum of $W_1 + W_2$ must equal W_o , within 25% or the test is invalid. For most compounds tested by this procedure, % RE_d values are generally less than % SE values determined per Section 14.2. The purpose of the static RE_d determination is to establish any loss or gain of analyte unrelated to the flow of nitrogen or air through the PUF plug.

15. Performance Criteria and Quality Assurance

[Note: This section summarizes required quality assurance (QA) measures and provides guidance concerning performance criteria that should be achieved within each laboratory.]

15.1 Standard Operating Procedures (SOPs)

15.1.1 Users should generate SOPs describing the following activities accomplished in their laboratory: (1) assembly, calibration, and operation of the sampling system, with make and model of equipment used; (2) preparation, purification, storage, and handling of sampling cartridges; (3) assembly, calibration, and operation of the analytical system, with make and model of equipment used; and (4) all aspects of data recording and processing, including lists of computer hardware and software used.

15.1.2 SOPs should provide specific stepwise instructions and should be readily available to, and understood by, the laboratory personnel conducting the work.

15.2 Process, Field, and Solvent Blanks

15.2.1 One PUF cartridge from each batch of approximately twenty should be analyzed, without shipment to the field, for the compounds of interest to serve as a process blank.

15.2.2 During each sampling episode, at least one PUF cartridge should be shipped to the field and returned, without drawing air through the sampler, to serve as a field blank.

15.2.3 Before each sampling episode, one PUF plug from each batch of approximately twenty should be spiked with a known amount of the standard solution. The spiked plug will remain in a sealed container and will not be used during the sampling period. The spiked plug is extracted and analyzed with the other samples. This field spike acts as a quality assurance check to determine matrix spike recoveries and to indicate sample degradation.

15.2.4 During the analysis of each batch of samples, at least one solvent process blank (all steps conducted but no PUF cartridge included) should be carried through the procedure and analyzed.

15.2.5 All blank levels should not exceed 10 ng/sample for single components or 100 ng/sample for multiple component mixtures (i.e., for organochlorine pesticides and PCBs).

15.3 Sampling Efficiency and Spike Recovery

15.3.1 Before using the method for sample analysis, each laboratory must determine its sampling efficiency for the component of interest as per Section 14.

15.3.2 The PUF in the sampler is replaced with a hexane-extracted PUF. The PUF is spiked with a microgram level of compounds of interest by dropwise addition of hexane solutions of the compounds. The solvent is allowed to evaporate.

15.3.3 The sampling system is activated and set at the desired sampling flow rate. The sample flow is monitored for 24 hours.

15.3.4 The PUF cartridge is then removed and analyzed as per Section 12.

15.3.5 A second sampler, unspiked, is collected over the same time period to account for any background levels of components in the ambient air matrix.

15.3.6 In general, analytical recoveries and collection efficiencies of 75% are considered to be acceptable method performance.

15.3.7 Replicate (at least triplicate) determinations of collection efficiency should be made. Relative standard deviations for these replicate determinations of $\pm 15\%$ or less are considered acceptable performance.

15.3.8 Blind spiked samples should be included with sample sets periodically as a check on analytical performance.

15.4 Method Precision and Bias

15.4.1 Precision and bias in this type of analytical procedure are dependent upon the precision and bias of the analytical procedure for each compound of concern, and the precision and bias of the sampling process.

15.4.2 Several different parameters involved in both the sampling and analysis steps of this method collectively determine the precision and bias with which each compound is detected. As the volume of air sampled is increased, the sensitivity of detection increases proportionately within limits set by: (a) the retention efficiency for each specific component trapped on the polyurethane foam plug, and (b) the background interference associated with the analysis of each specific component at a given site sampled. The sensitivity of detection of samples recovered by extraction depends on: (a) the inherent response of the particular GC detector used in the determinative step, and (b) the extent to which the sample is concentrated for analysis. It is the responsibility of the analyst(s) performing the sampling and analysis steps to adjust parameters so that the required detection limits can be obtained.

15.4.3 The reproducibility of this method for most compounds for which it has been evaluated has been determined to range from ± 5 to $\pm 30\%$ (measured as the relative standard deviation) when replicate sampling cartridges are used ($N > 5$). Sample recoveries for individual compounds generally fall within the range of 90 to 110%, but recoveries ranging from 65 to 125% are considered acceptable. PUF alone may give lower recoveries for more volatile compounds (i.e., those with saturation vapor pressures $> 10^{-3}$ mm Hg). In those cases, another sorbent or a combination of PUF and Tenax TA (see Figure 2) should be employed.

15.5 Method Safety

15.5.1 This procedure may involve hazardous materials, operations, and equipment. This method does not purport to address all of the safety problems associated with its use.

15.5.2 It is the user's responsibility to consult and establish appropriate safety and health practices and determine the applicability of regulatory limitations prior to the implementation of this procedure. This should be part of the user's SOP manual.

16. References

1. "Standard Practice for Sampling and Analysis of Pesticides and Polychlorinated Biphenyls in Air," *Annual Book of ASTM Standards*, Method D4861-94, ASTM, Philadelphia, PA.

2. Lewis, R., and MacLeod, K., "Portable Sampler for Pesticides and Semi-volatile Industrial Organic Chemicals in Air," *Analytical Chemistry*, Vol. 54, 1982, pp. 310-315.
3. Whitmore R.W., Immerman, F.W., Camann, D.E., Bond, A.E., Lewis, R.G., and Schaum, J.L., "Non-occupational Exposure to Pesticides for Residents of Two U.S. Cities," *Arch. Environ. Contam. Toxicol.*, 26, 47-59 (1994).
4. Lewis, R., and Brown, A., and Jackson, M., "Evaluation of Polyurethane Foam for Sampling of Pesticides, Polychlorinated Biphenyls and Polychlorinated Naphthalenes in Ambient Air," *Analytical Chemistry*, Vol. 49, 1977, pp. 1668-1672.
5. Armour, J., and Burke, J., "Method for Separating Polychlorinated Biphenyls from DDT and Its Analogs," *Journal of the Association of Official Analytical Chemists*, Vol. 53, No. 4, 1970, pp. 761-768.
6. *Manual of Analytical Methods for the Analysis of Pesticides in Human and Environmental Samples*, U. S. Environmental Protection Agency, Research Triangle Park, NC 27711, Report No. EPA-600/8-80-038, June 1980 (NTIS No. PB82-208752).
7. Kogan, V., Kuhlman, M., Coutant, R., and Lewis, R., "Aerosol Filtration in Sorbent Beds," *Journal of the Air and Waste Management Association*, Vol. 43, 1993, p. 1367-1373.
8. Lewis, R., and Lee, R., "Air Pollution from Pesticide Sources, Occurrences and Dispersion," In: *Air Pollution from Pesticides and Agricultural Processes*, Lee, R., Editor, CRC Press, Boca Raton, FL, 1976, pp. 51-94.
9. Lewis, R., "Problem Associated with Sampling for Semi-volatile Organic Chemicals in Air," *Proceedings of the 1986 EPA/APCA Symposium on Measurement of Toxic Air Pollutants*, Air and Waste Management Association, Pittsburgh, PA, 1986, pp. 134-145.
10. Camann, D., Harding, J., and Lewis, R., "Trapping of Particle-Associated Pesticides in Indoor Air by Polyurethane Foam and Evaporation of Soil Track-In as a Pesticide Source," In: *Indoor Air '90*, Vol. 2, Walkinshaw, D., editor, Canada Mortgage and Housing Corp., Ottawa, 1990, pp. 621-626.
11. Marple, V., Rubow, K., Turner, W., and Spengler, J., "Low Flow Rate Sharp Cut Impactors for Indoor Air Sampling Design and Calibration," *Journal of the Air Pollution Control Association*. Vol. 37, 1987, pp. 1303-1307.
12. Hsu, J., Wheeler, H., Camann, D., Shatterberg, H., Lewis, R., and Bond, A., "Analytical Methods for Detection of Nonoccupational Exposure to Pesticides," *Journal of Chromatographic Science*, Vol. 26, 1988, pp. 181-189.

TABLE 1. COMPOUNDS FOR WHICH PROCEDURE HAS BEEN TESTED¹

Compound	Recommended Analysis ²	Compound	Recommended Analyses
Alachlor	GC/ECD	Heptachlor	GC/ECD
Aldrin	GC/ECD	Heptachlor epoxide	GC/ECD
Allethrin	HPLC/UV	Hexachlorobenzene	GC/ECD
Aroclor 1242	GC/ECD	Hexachlorocyclopentadiene ^{3,4}	GC/ECD
Aroclor 1254	GC/ECD	Lindane (γ -BHC)	GC/ECD
Aroclor 1260	GC/ECD	Linuron	HPLC/UV
Atrazine	GC/NPD	Malathion	GC/NPD or FPD
Bendiocarb	HPLC/UV	Methyl parathion	GC/NPD or FPD
BHC (α - and β -Hexachlorocyclohexanes)	GC/ECD	Methoxychlor	GC/FCD
Captan	GC/ECD	Metolachlor	GC/ECD
Carbaryl	HPLC/UV	Mexacarbate	GC/FCD
Carbofuran	HPLC/UV	Mirex	GC/ECD
Chlordane, technical	GC/ECD	Monuron	HPLC/UV
Chlorothalonil	GC/ECD	Trans-nonachlor	GC/ECD
Chlorotoluron	HPLC/UV	Oxychlordane	GC/ECD
Chlorpyrifos	GC/ECD	Pentachlorobenzene	GC/ECD
2,4-D esters and salts	GC/ECD	Pentachlorophenol	GC/ECD
Dacthal	GC/ECD	Permethrin (cis and trans)	HPLC/UV
p,p' -DDT	GC/ECD	o -Phenylphenol	HPLC/UV
p,p' -DDE	GC/ECD	Phorate	GC/NPD or FPD
Diazinon	GC/NPD or FPD	Propazine	GC/NPD
Dicloran	GC/ECD	Propoxur (Baygon)	HPLC/UV
Dieldrin	GC/ECD	Pyrethrin	HPLC/UV
Dichlorvos (DDVP)	GC/ECD	Resmethrin	HPLC/UV
Dicofol	GC/ECD	Ronnel	GC/ECD
Dicrotophos	HPLC/UV	Simazine	HPLC/UV
Diuron	HPLC/UV	Terbutiuron	HPLC/UV
Ethyl parathion	GC/NPD or FPD	1,2,3,4-tetrachlorobenzene ³	GC/ECD
Fenvalerate	HPLC/UV	1,2,3-trichlorobenzene ³	GC/ECD
Fluometuron	HPLC/UV	2,3,5-trichlorophenol	GC/ECD
Folpet	GC/ECD	Trifluralin	GC/ECD

¹The following recommendations are specific for that analyte for maximum sensitivity.

²GC = gas chromatography; ECD = electron capture detector, FPD = flame photometric detector; HPLC = high performance liquid chromatography; NPD = nitrogen-phosphorus detector; UV = ultraviolet absorption detector, (GC/MS (gas chromatography/mass spectrometry) may also be used).

³Using PUF/Tenax-TA "sandwich" trap.

⁴Compound is very unstable in solution.

TABLE 2. SAMPLING EFFICIENCIES FOR SOME ORGANOCHLORINE PESTICIDES

Compound	Quantity Introduced, μg^2	Air Volume, m^3	Sampling efficiency, %		
			mean	RSD	n
α -Hexachlorocyclohexane (α -BHC)	0.005	0.9	115	8	6
γ -Hexachlorocyclohexane (Lindane)	0.05-1.0	0.9	91.5	8	5
Chlordane, technical	0.2	0.9	84.0	11	8
p,p'-DDT	0.6, 1.2	0.9	97.5	21	12
p,p'-DDE	0.2, 0.4	0.9	102	11	12
Mirex	0.6, 1.2	0.9	85.9	22	7
2,4-D Esters:					
Isopropyl	0.5	3.6	92.0	5	12
Butyl	0.5	3.6	82.0	10	11
Isobutyl	0.5	3.6	79.0	20	12
Isoctyl	0.5	3.6	>80 ²	--	--

¹Air volume = 0.9 m^3 .

²Not vaporized. Value base on %RE = 81.0 (RSD = 10%, n = 6).

TABLE 3. SAMPLING EFFICIENCIES FOR ORGANOPHOSPHORUS PESTICIDES

Compound	Quantity Introduced, μg^2	Sampling efficiency, %		
		mean	RSD	n
Dichlorvos (DDVP)	0.2	72.0	13	2
Ronnel	0.2	106	8	12
Chlorpyrifos	0.2	108	9	12
Diazinon ¹	1.0	84.0	18	18
Methyl parathion ¹	0.6	80.0	19	18
Ethyl parathion ¹	0.3	75.9	15	18
Malathion ¹	0.3	100 ³	--	--

¹Analyzed by gas chromatography with nitrogen phosphorus detector or flame photometric detector.

²Air volume = 0.9 m^3 .

³Decomposed in generator; value based on %RE = 101 (RDS = 7, n = 4).

TABLE 4. SAMPLING EFFICIENCIES FOR SOME SEMI-VOLATILE
ORGANOCHLORINE COMPOUNDS AND PCBs

Compound	Quantity Introduced, μg^1	Sampling efficiency, %		
		mean	RSD	n
1,2,3-Trichlorobenzene	1.0	6.6 ²	22	8
1,2,3,4-Tetrachlorobenzene	1.0	62.3 ²	33	5
Pentachlorobenzene	1.0	94.0	12	5
Hexachlorobenzene	0.5, 1.0	94.5	8	5
Hexachlorocyclopentadiene	1.0	8.3 ²	12	5
2,4,5-Trichlorophenol	1.0	108	3	5
Pentachlorophenol	1.0	107	16	5
Aroclor 1242	0.1	96.0	15	6
Aroclor 1254	0.1	95.0	7	6
Aroclor 1260	0.1	109	5	11

¹Air volume = 0.9 m³.

²% SEs were 98, and 97% (n = 2), respectively, for these three compounds by the PUF/Tenax® TA "sandwich" trap.

TABLE 5. SAMPLING EFFICIENCIES FOR CARBAMATES, UREAS, TRIAZINES, AND PYRETHRINS

Compound	Spike Level, µg/plug	Static Recovery, %		n	Retention Efficiency, %		n	Sampling Efficiency, %		n
		mean	RSDP		mean	RSD		mean	RSD	
Carbamates:										
Propoxur	5	61.4	10	6	77.6	37	6	96.7	11	6
Carbofuran	15	55.3	12	6	64.2	46	6	87.2	14	6
Bendicarb	50	57.3	11	6	69.8	43	6	62.1	14	6
Mexacarbamate	10	62.8	19	6	62.7	41	6	89.8	14	6
Carbaryl	100	56.6	14	6	63.6	53	6	0	13	6
Ureas:										
Monuron	19	87.0	6	6	91.2	6	5	0		
Diuron	20	84.1	8	6	90.0	2	5	0		
Linuron	20	86.7	8	6	92.5	4	5	0		
Terbutiuron	18	85.0	8	6	88.8	8	5	0		
Fluometuron	20	91.4	10	6	101	3	5	0		
Chlortoluron	20	86.2	11	6	92.0	7	5	0		
Triazines:										
Simazine	10	103	6	5	101	9	6	0		
Atrazine	10	104	7	5	98.9	7	6	0		
Propazine	10	105	11	5	99.9	14	6	0		
Pyrethrins:										
Pyrethrin I	(9.7)	90.5	10	6	95.6	22	5	0		
Pyrethrin II	(6.1)	88.6	11	6	69.9	29	5	0		
Allethrin	25	69.2	9	5	58.3	12	6	0		
d-trans-Allethrin	25	76.8	9	6	74.4	9	5	0		
Dicrotophos	25	72.0	22	6	71.7	8	5	0		
Resmethrin	25	76.5	14	6	66.7	14	6	0		
Fenvalerate	25	87.9	3	6	57.2	20	3	0		

TABLE 6. EXTRACTION AND 24-H SAMPLING EFFICIENCIES FOR VARIOUS PESTICIDES AND RELATED COMPOUNDS

Compound	Extraction Efficiency, %		Sampling Efficiency, %, at					
	10 ng/m ³		100 ng/m ³		1,000 ng/m ³			
	mean	RSD	mean	RSD	mean	RSD	mean	RSD
Chlorpyrifos	83.3	11.5	83.7	18.0	92.7	15.1	83.7	18.0
Pentachlorophenol	84.0	22.6	66.7	42.2	52.3	36.2	66.7	42.2
Chlordane	95.0	7.1	96.0	1.4	74.0	8.5	96.0	1.4
o-Phenylphenol	47.0	46.7	46.0	19.1	45.3	29.9	46.0	19.1
Lindane	96.0	6.9	91.7	11.6	93.0	2.6	91.7	11.6
DDVP	88.3	20.2	51.0	53.7	106.0	1.4	51.0	53.7
2,4-D Methyl Ester	--	--	75.3	6.8	58.0	23.6	75.3	6.8
Heptachlor	99.0	1.7	97.3	13.6	103.0	17.3	97.3	13.6
Aldrin	97.7	4.0	90.7	5.5	94.0	2.6	90.7	5.5
Dieldrin	95.0	7.0	82.7	7.6	85.0	11.5	82.7	7.6
Ronnel	80.3	19.5	74.7	12.1	60.7	15.5	74.7	12.2
Diazinon	72.0	21.8	63.7	18.9	41.3	26.6	63.7	19.9
trans-Nonachlor	97.7	4.0	96.7	4.2	101.7	15.3	96.7	4.2
Oxychlorodane	100.0	0.0	95.3	9.5	94.3	1.2	95.3	9.5
α-BHC	98.0	3.5	86.7	13.7	97.0	18.2	86.7	13.7
Bendiocarb	81.3	8.4	59.7	16.9	30.7	23.5	59.7	16.9
Chlorothalonil	90.3	8.4	76.7	6.1	70.3	6.5	76.7	6.1
Heptachlor Epoxide	100.0	0.0	95.3	5.5	97.7	14.2	95.3	5.5
Dacthal	--	--	87.0	9.5	95.3	22.2	87.0	9.5
Aroclor 1242	91.7	14.4	95.0	15.5	94.7	17.5	95.0	15.5

¹Mean values for one spike at 550 ng/plug and two spikes at 5,500 ng/plug.

²Mean values for three determinations.

TABLE 7. EXTRACTION AND 24-H DYNAMIC RETENTION EFFICIENCIES FOR VARIOUS PESTICIDES AND RELATED COMPOUNDS

Compound	Extraction Efficiency, %		Sampling Efficiency ² , % at					
	10 ng/m ³		100 ng/m ³		1,000 ng/m ³			
	mean	RSD	mean	RSD	mean	RSD	mean	RSD
Propoxur	77.5	71.4	92.0	--	91.7	22.8	101.0	18.4
Resmethrin	95.5	71.4	79.0	--	100.7	13.1	107.0	4.4
Dicofol	57.0	8.5	38.0	25.9	65.0	8.7	69.0	--
Captan	73.0	12.7	56.0	--	45.5	64.3	84.3	16.3
Carbaryl	74.0	82.0	102.0	--	61.0	--	113.0	6.1
Malathion	76.5	44.5	108.0	--	54.0	16.0	77.3	7.6
cis-Permethrin	88.7	10.3	101.0	28.5	85.0	26.9	89.0	11.3
trans-Permethrin	88.7	11.0	67.3	34.8	80.7	56.4	108.3	9.5
Methoxychlor	65.5	4.9	--	--	--	--	78.5	2.1
Atrazine	75.0	50.5	--	--	73.0	30.1	83.0	9.5
Folpet	86.7	11.7	--	--	78.0	--	93.0	--
Aroclor 1260	92.0	14.5	88.0	9.6	85.3	9.9	107.1	13.6

¹Mean values for one spike at 550 ng/plug and two spikes at 5,500 ng/plug.²Mean values for three determinations.

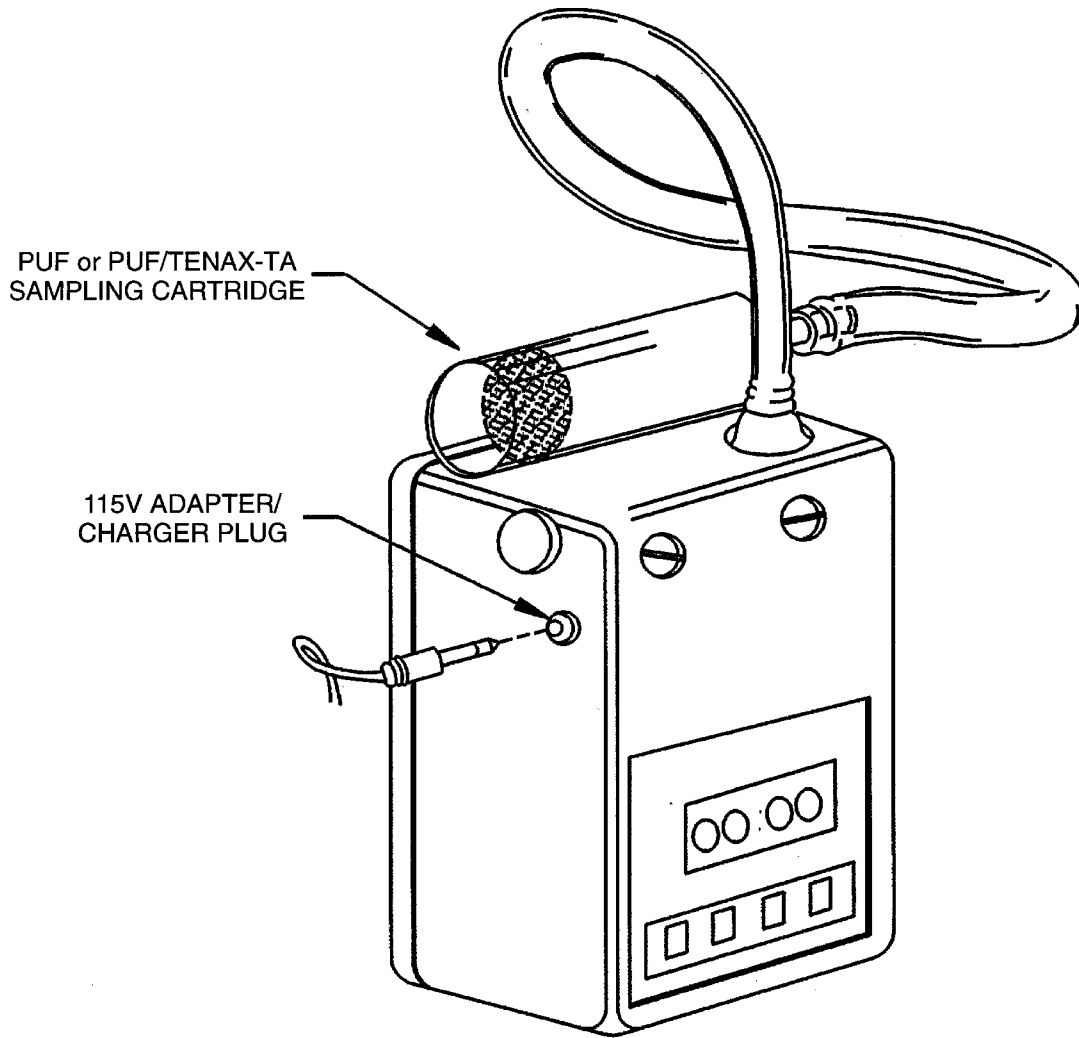

Figure 1. Low volume air sampler.

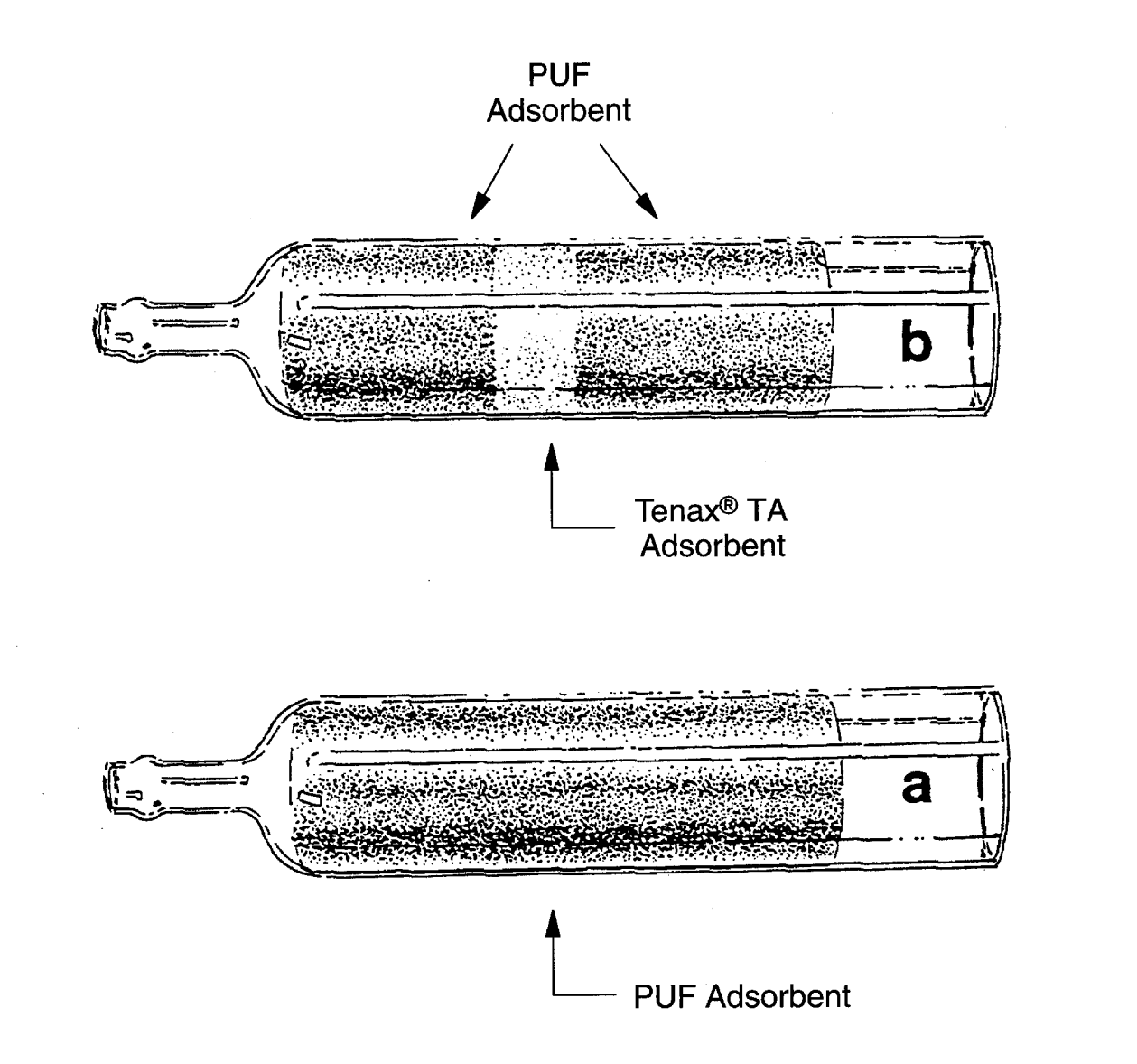

Figure 2. Polyurethane foam (PUF) sampling cartridge (a) and PUF-Tenax® TA "sandwich" sampling cartridge (b).

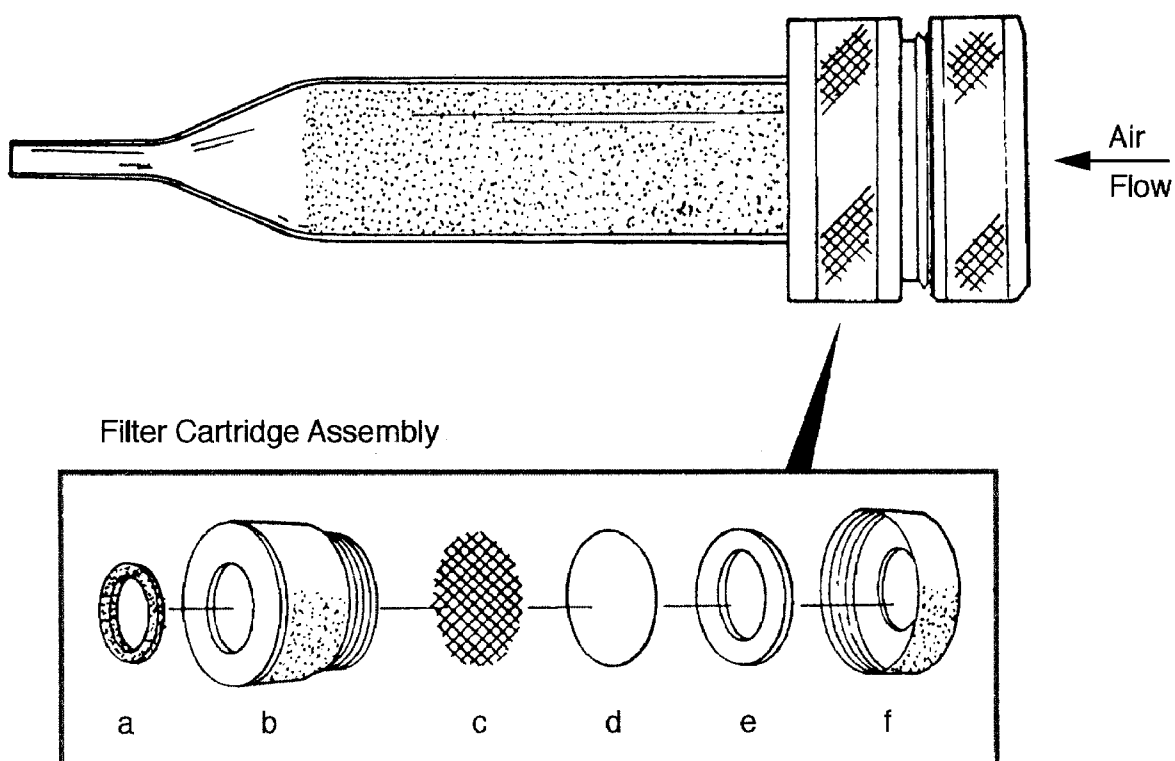

Figure 3. Open-face filter assembly attached to a PUF cartridge:
(a) Inner Viton® o-ring, (b) filter cartridge, (c) stainless steel screen, (d) quartz filter,
(e) filter ring, and (f) cartridge screw cap.

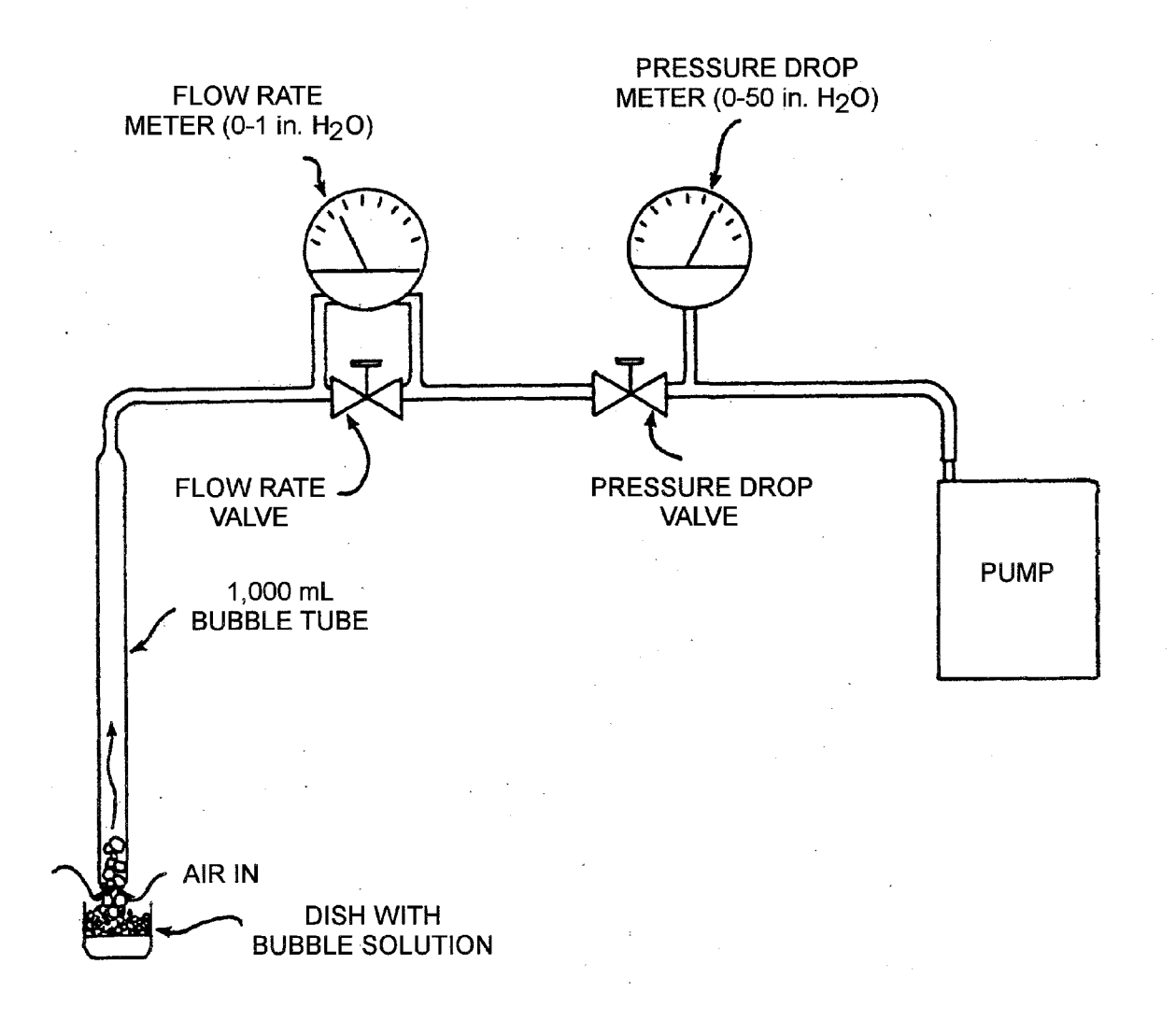

Figure 4. Calibration assembly for air sampler pump.

**COMPENDIUM METHOD TO-10A
FIELD TEST DATA SHEET (FTDS)**

I. GENERAL INFORMATION

PROJECT: _____ DATE(S) SAMPLED: _____
 SITE: _____ TIME PERIOD SAMPLED: _____
 LOCATION: _____ OPERATOR: _____
 INSTRUMENT MODEL NO.: _____ CALIBRATED BY: _____
 PUMP SERIAL NO.: _____ RAIN: ___ YES ___ NO

ADSORBENT CARTRIDGE INFORMATION:

	Cartridge 1	Cartridge 2	Cartridge 3	Cartridge 4
Type:	_____	_____	_____	_____
Adsorbent:	_____	_____	_____	_____
Serial No.:	_____	_____	_____	_____

Sample No.:	_____	_____	_____	_____

II. SAMPLING DATA

Cartridge Identification	Sampling Location	Ambient Temp., °F	Ambient Pressure, in Hg	Flow Rate (Q), mL/min		Sampling Period		Total Sampling Time, min.	Total Sample Volume, L
				Cartridge 1	Cartridge 2	Start	Stop		

III. FIELD AUDIT

	<u>Cartridge 1</u>	<u>Cartridge 2</u>	<u>Cartridge 3</u>	<u>Cartridge 4</u>
Audit Flow Check Within	_____	_____	_____	_____
10% of Set Point (Y/N)?	pre-	pre-	pre-	pre-
	_____	_____	_____	_____
	post-	post-	post-	post-

CHECKED BY: _____

DATE: _____

Figure 5. Compendium Method TO-10A field test data sheet.

OPERATING CONDITIONS

Column Type: DB-5 0.32 capillary,
0.25 um film thickness
Column Temperature Program: 90°C(4min)/16°C per min to
154°C/4°C per min to 270°C.
Detector: Electron Capture
Carrier Gas: Helium at 1 mL/min.
Make Up Gas: 5% Methane/95% Argon at 60 mL/min.

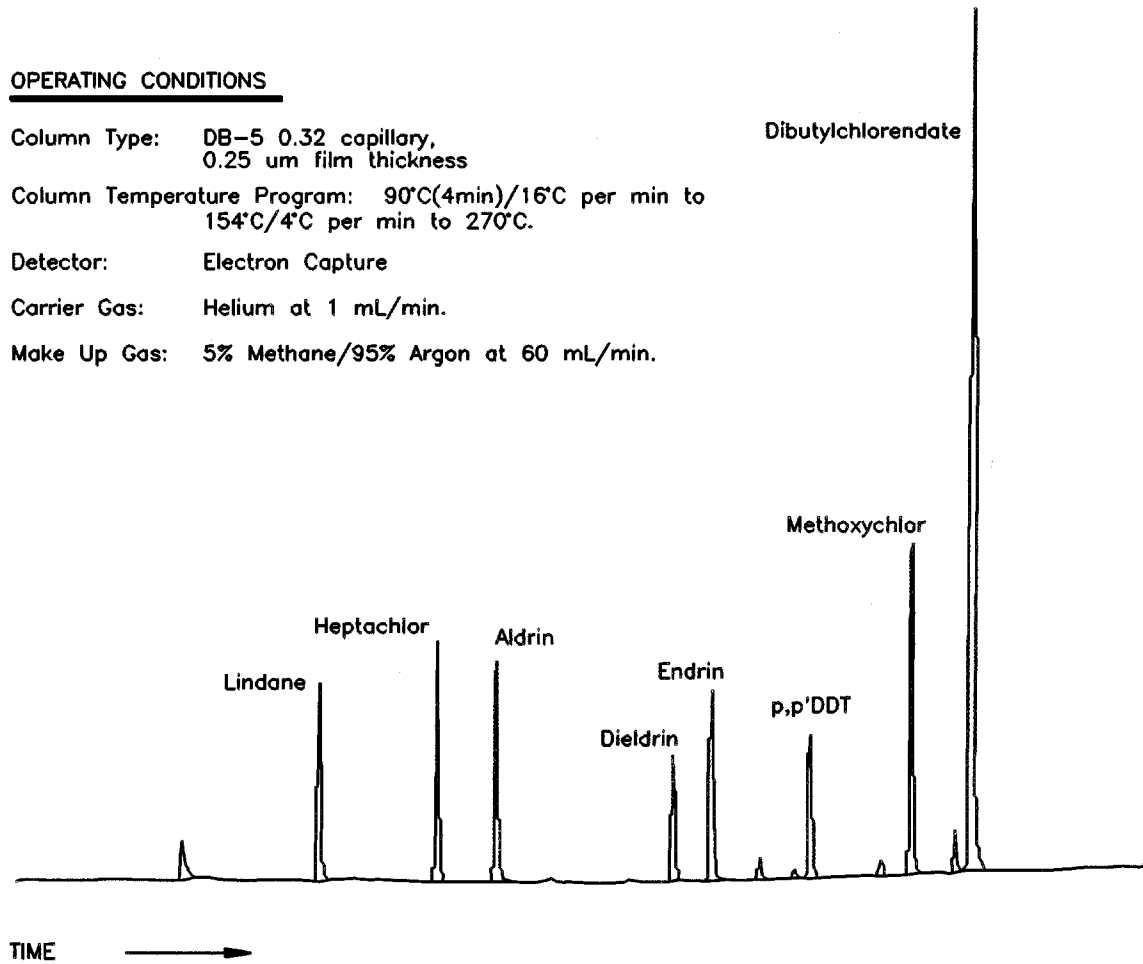

Figure 6. Chromatogram showing a mixture of single component pesticides determined by GC/ECD using a capillary column.

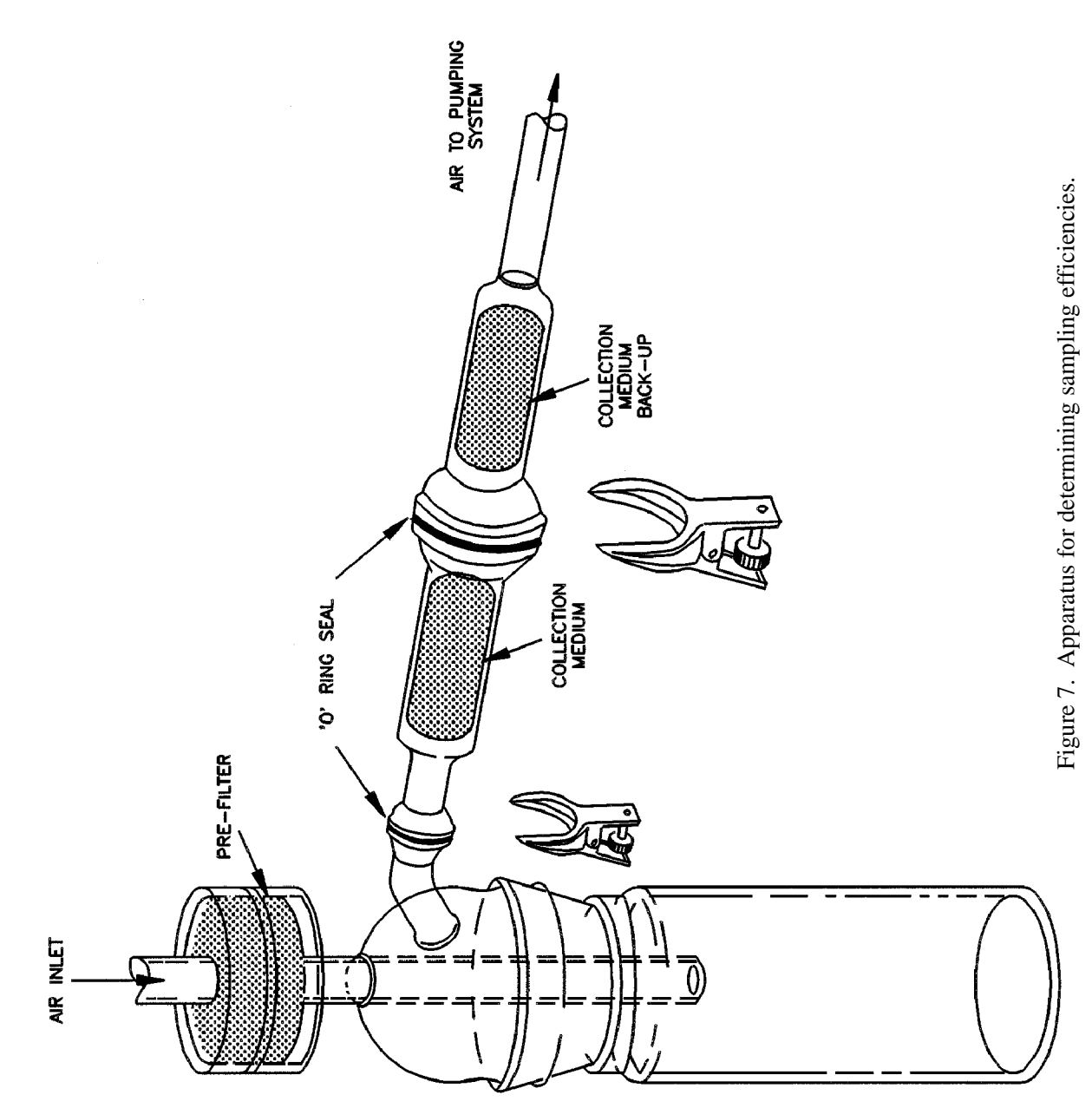

Figure 7. Apparatus for determining sampling efficiencies.



Attachment D

Asbestos-Containing Material
(ACM) Paint Sampling and
Analyses



ARCADIS of New York, Inc.
6723 Towpath Road
P O Box 66
Syracuse
New York 13214-0066
Tel 315 446 9120
Fax 315 449 0017
www.arcadis-us.com

Peter Ramanauskas
U.S. EPA Region 5
77 W. Jackson Blvd
Chicago, IL 60604

ENVIRONMENT

Subject:

GE Aviation – Cincinnati/Altitude Test Facility
Asbestos-Containing Material (ACM) Paint Sampling and Analyses

Date:

June 18, 2013

Dear Mr. Ramanauskas:

As a follow-up to the April 25, 2013 meeting with US EPA Region 5 at your offices in Chicago, GE Aviation, an operating division of the General Electric Company (GE), recently conducted ACM sampling and analyses of the paint from the Altitude Test Facility at GE's facility in Cincinnati, Ohio.

ARCADIS personnel collected a total of eleven (11) paint chip samples from various locations of the ATF duct piping network from the painted surfaces of exposed steel pipe, associated appurtenances, and structural supports, roughly corresponding to areas from which samples were taken for purposes of PCB analyses. Samples were taken of the two types of paint likely to be disturbed during the implementation of GE's Long-Term Remediation Plan for the ATF.

Sampling was conducted by qualified environmental technicians who collected paint chip samples via pipe scraping and placement of paint chips in lock-tite plastic baggies. Samples were sent to an Ohio-licensed ACM laboratory (ALS Laboratory Group) for testing in accordance with EPA's "Method for the Determination of Asbestos in Bulk Building Materials" – EPA/600/R-93/116 (July 1993), using Transmission Electron Microscopy (TEM). Samples, described by the lab as "gray crumbly paint" and "metallic gray crumbly paint," consisted of paint chips that were collected in zip lock bags for testing. The analytical results for all eleven paint chip samples were "non-detect" for ACM. Copies of the testing reports are included as an attachment to this letter.

In addition to resolving the question regarding the potential presence of ACM in the paint, ARCADIS looked into the issue of gaskets and “plaster” materials. Some small areas around a few joints in the piping system are protected with a filler material (perhaps plaster), which is covered by a textile or fabric material. Each of these areas appears to be in good condition. The facility manages this material under the assumption that it is potentially ACM, and has places warning labels in appropriate locations. It is also ARCADIS’ understanding that some flanged fittings contain gasket materials (due to the design of the piping system, the gasket material is not readily accessible). Some areas of the facility already contain placards warning that such gaskets may contain asbestos. As part of any future ATF duct piping network removal or repair work, if filler material and/or gaskets are encountered, they will be considered ACM for removal purposes, unless tested otherwise. The revised long-term plan will reflect this approach.

We hope this satisfies ACM questions that were raised during our meeting with US EPA in April (with the exception of the additional detail of the asbestos management procedures GE intends to employ, which will be in the revised long-term plan).

Please do not hesitate to contact me at (716) 525-6113 if you have any questions.

Sincerely,

ARCADIS of New York, Inc.



John F. Novotny, PE
Senior Engineer

Attachments

ALS Reports

Copies:

Susan Perdomo, USEPA
Jeffrey Bratko, USEPA
Brad Grams, USEPA
John Rumpf, GE
Jennifer Hardenbrook, GE
Christopher Bell, Sidley Austin, LL



Attachment A

Analytical Testing Report



Submitted To: John Novotny
ARCADIS LEXINGTON
2464 Fortune Drive Siute 100
Lexington KY 40509

Test Report
Page 1 of 3
5/3/13

REFERENCE DATA

Sample Type:	Asbestos by TEM with Gravimetric Reduction
Method Reference:	Nonfriable Bulk Material with Organic Binder
Client Sample Nos.:	EPA/600/R-93/116, Chatfield Method
Sample Location:	ATF-PC-T0502-01 through ATF-PC-T0502-10
PO No.:	GE Aviation; Project No.: B0031231.0000.00002
ALS Work Order No.:	Not provided
ALS Sample Nos.:	1305050
Sample Receipt Date:	1305050-01 through 1305050-10
Preparation Date:	5/2/2013
Analysis Date:	5/2/2013 through 5/3/2013
	5/3/2013

We certify that the samples indicated on the following data sheet(s) were analyzed by Transmission Electron Microscopy (TEM) for asbestos using the method, EPA/600/R-93/116, Chatfield Method, for determining the amount and type of asbestos present in bulk building materials.

After an initial examination by stereomicroscope to determine homogeneity, friability, matrix material and other characteristics, we prepared the samples using gravimetric reduction. Coarse, non-asbestos materials that cannot be pulverized, such as pebbles or metal foils, were separated from the portion analyzed. Other non-asbestos material was removed by ashing in a muffle furnace and/or dissolution in decalcifying solution. Sample weights were tracked through each step in the reduction.

Analysis was performed on an FEI Tecnai Spirit Twin TEM and EDAX Genesis System using energy dispersive X-ray analysis (EDXA) spectra and selected area electron diffraction (SAED) patterns to determine fiber species. Asbestos percentages are based on a visual estimate of the asbestos percent by area in the final residue and are listed on the following data sheet(s). Results apply only to portions of samples analyzed. ALS Laboratory Group Environmental Division (Cincinnati) will dispose of all bulk samples after 60 days unless other arrangements are made.

Pamela Johnson
Analyst

Shawn Smythe
Project Manager

This report shall not be reproduced except in full, without written approval of ALS Environmental.



CLIENT: ARCADIS LEXINGTON
SAMPLE LOCATION: GE Aviation; Project No.: B0031231.0000.00002

ANALYSIS DATA

EDXA Resolution: 133.66 eV Magnification: 9,800 X
 Accelerating Voltage: 100 keV Calibration Constant: 1 cm = 1.02 μm
 Camera Constant: 129.25 mm-Å

SAMPLE IDENTIFICATION					
Client Sample No.:	ATF-PC-T0502-01	ATF-PC-T0502-02	ATF-PC-T0502-03	ATF-PC-T0502-04	ATF-PC-T0502-05
ALS Sample No.:	1305050-01	1305050-02	1305050-03	1305050-04	1305050-05
SAMPLE DESCRIPTION					
Homogeneity:	Homogeneous	Homogeneous	Homogeneous	Homogeneous	Homogeneous
Color:	Gray	Gray	Gray	Gray	Gray
Texture:	Crumbly	Crumbly	Crumbly	Crumbly	Crumbly
Description:	Paint	Paint	Paint	Paint	Paint
SAMPLE PREP					
Starting Weight (g):	0.0743	0.1014	0.1082	0.1752	0.2803
Residue Weight (g):	0.0327	0.0564	0.0593	0.0957	0.1505
Weight Percent Residue:	44.01	55.62	54.81	54.62	53.69
PERCENT ASBESTOS DETECTED IN RESIDUE					
Chrysotile:	0	0	0	0	0
Amosite:	0	0	0	0	0
Crocidolite:	0	0	0	0	0
Actinolite-Tremolite:	0	0	0	0	0
Anthophyllite:	0	0	0	0	0
TOTAL IN RESIDUE	ND	ND	ND	ND	ND
ASBESTOS PERCENT IN SAMPLE					
	ND	ND	ND	ND	ND

ND = None Detected TRACE = <1%

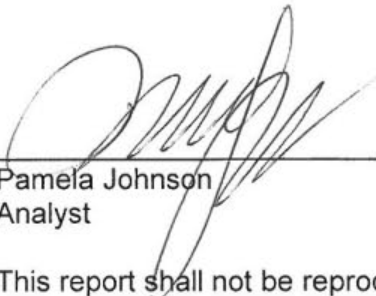
 Pamela Johnson
 Analyst

 Shawn Smythe
 Project Manager

This report shall not be reproduced except in full, without written approval of ALS Environmental.



CLIENT: ARCADIS LEXINGTON
SAMPLE LOCATION: GE Aviation; Project No.: B0031231.0000.00002

ANALYSIS DATA

EDXA Resolution: 133.66 eV Magnification: 9,800 X
 Accelerating Voltage: 100 keV Calibration Constant: 1 cm = 1.02 μm
 Camera Constant: 129.25 mm-Å

SAMPLE IDENTIFICATION					
Client Sample No.:	ATF-PC-T0502-06	ATF-PC-T0502-07	ATF-PC-T0502-08	ATF-PC-T0502-09	ATF-PC-T0502-10
ALS Sample No.:	1305050-06	1305050-07	1305050-08	1305050-09	1305050-10
SAMPLE DESCRIPTION					
Homogeneity:	Homogeneous	Homogeneous	Homogeneous	Homogeneous	Homogeneous
Color:	Gray	Gray	Gray	Gray	Gray
Texture:	Crumbly	Crumbly	Crumbly	Crumbly	Crumbly
Description:	Paint	Paint	Paint	Paint	Paint
SAMPLE PREP					
Starting Weight (g):	0.1687	0.1465	0.1452	0.1467	0.3760
Residue Weight (g):	0.0602	0.1046	0.0833	0.0678	0.3128
Weight Percent Residue:	35.68	71.40	57.37	46.22	83.19
PERCENT ASBESTOS DETECTED IN RESIDUE					
Chrysotile:	0	0	0	0	0
Amosite:	0	0	0	0	0
Crocidolite:	0	0	0	0	0
Actinolite-Tremolite:	0	0	0	0	0
Anthophyllite:	0	0	0	0	0
TOTAL IN RESIDUE	ND	ND	ND	ND	ND
ASBESTOS PERCENT IN SAMPLE					
	ND	ND	ND	ND	ND

ND = None Detected TRACE = <1%

 Pamela Johnson
 Analyst

 Shawn Smythe
 Project Manager

This report shall not be reproduced except in full, without written approval of ALS Environmental.



Submitted To: John Novotny
ARCADIS LEXINGTON
2464 Fortune Drive Suite 100
Lexington KY 40509

Test Report
Page 1 of 2
5/31/13

REFERENCE DATA

Sample Type:	Asbestos by TEM with Gravimetric Reduction
Method Reference:	Nonfriable Bulk Material with Organic Binder
Client Sample Nos.:	EPA/600/R-93/116, Chatfield Method
Sample Location:	ATF-PC-TB4-053113
PO No.:	GE Aviation; Project No.: B0031231.0000
ALS Work Order No.:	Not provided
ALS Sample Nos.:	1305681
Sample Receipt Date:	1305681-01
Preparation Date:	5/31/2013
Analysis Date:	5/31/2013

We certify that the samples indicated on the following data sheet(s) were analyzed by Transmission Electron Microscopy (TEM) for asbestos using the method, EPA/600/R-93/116, Chatfield Method, for determining the amount and type of asbestos present in bulk building materials.

After an initial examination by stereomicroscope to determine homogeneity, friability, matrix material and other characteristics, we prepared the samples using gravimetric reduction. Coarse, non-asbestos materials that cannot be pulverized, such as pebbles or metal foils, were separated from the portion analyzed. Other non-asbestos material was removed by ashing in a muffle furnace and/or dissolution in decalcifying solution. Sample weights were tracked through each step in the reduction.

Analysis was performed on an FEI Tecnai Spirit Twin TEM and EDAX Genesis System using energy dispersive X-ray analysis (EDXA) spectra and selected area electron diffraction (SAED) patterns to determine fiber species. Asbestos percentages are based on a visual estimate of the asbestos percent by area in the final residue and are listed on the following data sheet(s). Results apply only to portions of samples analyzed. ALS Laboratory Group Environmental Division (Cincinnati) will dispose of all bulk samples after 60 days unless other arrangements are made.

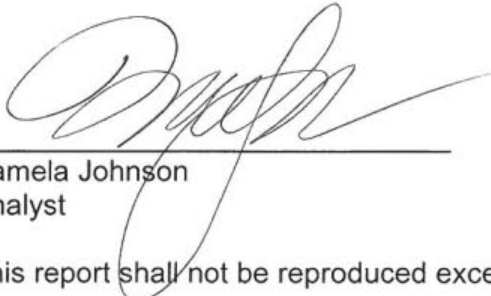

Pamela Johnson
Analyst



Shawn Smythe
Project Manager

This report shall not be reproduced except in full, without written approval of ALS Environmental.



CLIENT: ARCADIS LEXINGTON
SAMPLE LOCATION: GE Aviation; Project No.: B0031231.0000

ANALYSIS DATA

EDXA Resolution: 133.66 eV Magnification: 9,800 X
 Accelerating Voltage: 100 keV Calibration Constant: 1 cm = 1.02 μm

SAMPLE IDENTIFICATION	
Client Sample No.:	ATF-PC-TB4-053113
ALS Sample No.:	1305681-01
SAMPLE DESCRIPTION	
Homogeneity:	Homogeneous
Color:	Metallic Gray
Texture:	Crumbly
Description:	Paint
SAMPLE PREP	
Starting Weight (g):	0.1095
Residue Weight (g):	0.0590
Weight Percent Residue:	53.88
PERCENT ASBESTOS DETECTED IN RESIDUE	
Chrysotile:	0
Amosite:	0
Crocidolite:	0
Actinolite-Tremolite:	0
Anthophyllite:	0
TOTAL IN RESIDUE	ND
ASBESTOS PERCENT IN SAMPLE	
	ND

ND = None Detected

TRACE = <1%

 Pamela Johnson
 Analyst

 Shawn Smythe
 Project Manager

This report shall not be reproduced except in full, without written approval of ALS Environmental.



Attachment E

Multi-Layered Barrier Photos

ATF Ducting Insulation – Detail

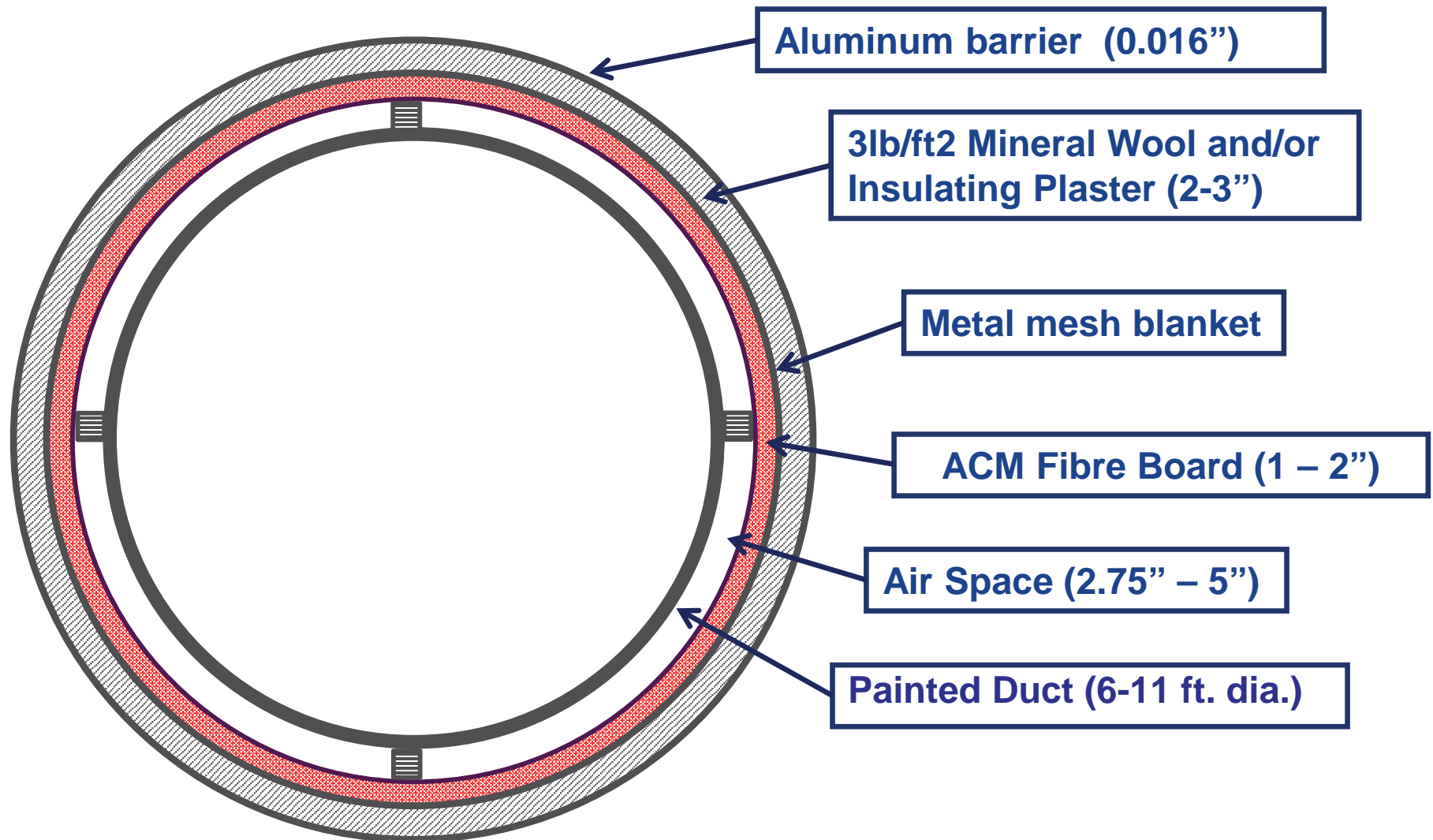

Note: Depicts typical insulation installation; not to scale

ATF Ducting Insulation – Photos





Attachment F

O&M Plan

General Electric Company

**Operations and Maintenance Plan
for the Altitude Test Facility (ATF)**

GE Aviation, Cincinnati, Ohio

December 2013



**Operations and Maintenance
Plan for the Altitude Test
Facility (ATF)**

GE Aviation
Cincinnati, Ohio

Prepared for:
General Electric Company

Prepared by:
ARCADIS U.S., Inc.
6723 Towpath Road
P O Box 66
Syracuse
New York 13214-0066
Tel 315 446 9120
Fax 315 449 0017

Our Ref.:
B0031231

Date:
December 2013

1. Introduction	1
2. Pipe with ACM Insulation and Barrier	2
2.1 Introduction	2
2.2 Description of the Insulating Barrier	2
2.3 Operation and Maintenance Plan For Pipe Encapsulated By The Insulating Barrier	4
2.3.1 Introduction	4
2.3.2 Piping Network Inspections	4
2.3.3 Pipe/Barrier Repair and Replacement	5
3. Waste Management	7
4. Maintenance Record Keeping	8

Attachments

A	Record Drawings
---	-----------------



1. Introduction

On December 19, 2012, the United States Environmental Protection Agency (USEPA) approved the use of the ATF, subject to the interim cleanup proposed by GE and certain other conditions. This Operations and Maintenance (O&M Plan) describes the post-remediation O&M activities associated with Altitude Test Facility (ATF) piping network. For further background information, refer to the Long-Term Remediation Plan (not attached).

The central elements of this O&M Plan are:

1. Maintain (and not disturb) the aluminum cladding and insulation, which forms a barrier to exposure to any PCB-containing paint that might remain on the exterior of the pipe.
2. Implement an operation and maintenance program pursuant to which the condition of the piping will be monitored and, over time and as necessary, be replaced. As the piping is replaced, any PCB-containing paint associated with such piping shall be properly managed and disposed.
3. Maintain the PCB M_L mark placed in appropriate locations, as well as the procedures regarding employee awareness and protection, and the management and disposal of PCB-containing waste.



2. Pipe with ACM Insulation and Barrier

2.1 Introduction

This portion of the Plan describes provisions of the operation and maintenance plan for the pipes that will remain in place for their useful life.

2.2 Description of the Insulating Barrier

Following the remediation activities, approximately 1,500 feet of the ATF system piping remains protected and covered by a multi-layered insulation barrier and aluminum sheathing, effectively encapsulating any PCB-containing paint on the exterior surface of the pipe. This encapsulation provides a barrier preventing any potential contact with the PCB-containing surface, thus preventing any risk to human health or the environment. Refer to **Attachment A – Record Drawings** for sections of piping that remain post-remediation, with PCB-containing paint (exterior of piping network only; covered by a multi-layer insulation barrier).

In summary, the following piping will remain:

- *Approximately 1,500 feet of piping (including 18-inch, 36-inch, 6-foot and 11-foot diameter) protected by the metal-clad barrier.*
- *Approximately 310 feet of this piping is located exterior to the ATF at elevated heights (20-25 feet above grade).*
- *Approximately 160 feet of piping is semi-enclosed. It runs between the air Inlet concrete structures and the main building wall of the ATF. This piping is located beneath elevated piping steel and the infrastructure used to support that elevated piping.*
- *The balance of the remaining piping, approximately 1,030 feet, is located inside of the ATF.*

This metal-clad barrier, depicted in Figure 1 below, consists of the following (interior to exterior):

- “High chairs” or “Spacers” of reinforced steel support the insulating barrier and create 2-5 inches of air space between the exterior of the pipe and the first layer of the barrier.
- The first component of the barrier, 2-5 inches from the pipe, is a double layer of galvanized metal mesh.
- The second layer is comprised of rigid asbestos-containing millboard that is 0.25 to 0.5 inches thick.
- The third layer is mineral wool 2-3 inches thick.
- The final layer is rigid aluminum cladding.

Figure 1: ATF Multi-Layered Barrier - Detail

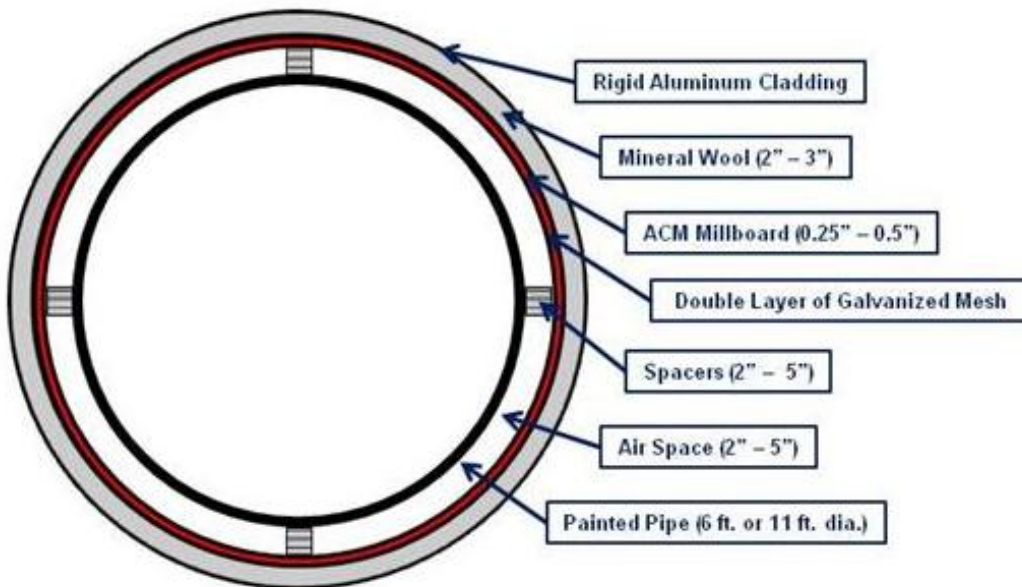

This multi-layered, metal-sheathed insulation on the pipes provides a fixed and rigid encapsulating barrier that prevents exposure to any PCB-containing paint that may be present on the exterior of the pipe. Long-term maintenance procedures are outlined in Section 2.3.



2.3 Operation and Maintenance Plan For Pipe Encapsulated By The Insulating Barrier

2.3.1 Introduction

Following remediation efforts in accordance with the Long-Term Remediation Plan, GE will inspect and maintain the balance of the piping that is encapsulated with the insulating barrier. This will prevent any exposure to PCB-containing paint that is on the surface of the pipe. In addition, the operation and maintenance plan will serve as the framework for replacing the pipe over time, which will necessarily result in the removal of any PCB-containing paint on its surface.

2.3.2 Piping Network Inspections

GE will conduct monthly piping network inspections in addition to monthly PCB M_L marker inspections. The ATF piping network inspection will include a visual inspection of the encapsulating barrier to verify that it is free from damage, including but not limited to, rusting, water damage, cracks, and/or breakage. These inspections will be performed along all accessible portions of the approximate 1,500-foot length of the encapsulated piping. Where necessary due to elevated piping and/or tight confines, GE will use alternate means (including but not limited to: man lifts, confined space entry permit, etc.) to gain limited access to the pipe network in order to complete the monthly pipe inspection. Any damage to the encapsulating barrier will be identified on an inspection log and will either be promptly repaired or addressed as part of a pipe or barrier replacement project, described in Section 2.3.3.

In addition, prior to conducting an engine test (but no less than monthly), GE will conduct a Foreign Object Debris (FOD) inspection of the entire interior of the piping network. In the event that any pipe damage is identified, GE will follow the same procedures as outlined above (i.e., complete an inspection log; promptly repair or address per Section 2.3.3). In addition to routine monthly visual inspections, the ATF piping network, including the encapsulating barrier, will be subject to a condition assessment by a third-party engineering firm every five years, beginning in Year 2015. This assessment will include the following elements:

- A comparison of current conditions to the design parameters of the piping network, including material specifications, design diameters, and wall thickness. It will include wall thickness testing at approximately 50-foot intervals along the length of pipe (not yet replaced).

- A summary of the operating parameters of the piping network, including design temperature and pressures.
- A description of any modifications, repairs or significant visual inspection findings since the last assessment.
- An assessment of the piping network's fitness for continued use (e.g., if > 50% of pipe wall thickness remains, then continued use is satisfactory).
- Any recommendations regarding the repair or replacement of portions of the piping system.

The findings from the third-party condition assessment will be summarized in a final report that will be maintained pursuant to Section 4.0 and be available for USEPA review. The need for any maintenance, repair, or replacement activities identified as a result of the condition assessment will be addressed as a pipe or barrier replacement project as described in Section 2.3.3.

2.3.3 Pipe/Barrier Repair and Replacement

In the event that the existing encapsulating barrier is damaged and cannot be promptly repaired, and thus requires replacement, appropriate GE Environmental Health and Safety (EHS) personnel will oversee the replacement operations. In general, the repair or replacement of the encapsulating barrier will be performed by an Ohio Department of Health (ODH)-licensed Asbestos Hazard Abatement Contractor, with appropriately certified personnel, to perform the abatement work. Under no circumstances will torch cutting or flame emitting devices be used when removing or repairing the paint-containing pipe. Waste generated by the barrier or pipe repair or removal activities, with the exception of the ACM encapsulating barrier, will be managed in accordance with Section 3.0.

Future pipe replacement efforts, including those arising from the inspections and recommendations described in Section 2.3.2, will be coordinated and overseen by GE EHS personnel. USEPA will be notified of any planned pipe replacement project at least 60 days prior to the commencement of any such project. Such a notification will identify the portions of the pipe intended to be replaced and the process for removing such pipe, including applicable measures to protect human health and the environment. In the event of an emergency condition requiring a major repair or replacement of pipe, the work will be conducted immediately and USEPA will be



**Operations and
Maintenance Plan for the
Altitude Test Facility**

GE Aviation
Cincinnati, Ohio

notified of the work within 1-2 business days. Minor repairs to the pipe will be completed per GE's on-site standard operating procedures (SOPs) with no USEPA notification.

Prior to disconnecting the pipe from the network, the encapsulating barrier surrounding the disconnection point will be abated per the procedure outlined in Section 4.3 of the Long-Term Remediation Plan. If the use of flame-emitting devices is used to sever the pipe, all PCB-containing paint will be removed in the area of the disconnection and all waste generated as a part of pipe replacement activities will be managed in accordance with Section 3.0. During pipe replacement, care will be taken not to use heated techniques (e.g., welding) when securing new piping to existing, PCB-containing painted piping. PCB-containing paint will be abated, as necessary, prior to securing new pipe. Documentation (e.g., waste manifests, bills of lading and/or certificates of disposal) will be maintained by GE as part of a continual record keeping program, described in Section 4.0.



3. Waste Management

Wastes generated from the activities subject to this O&M Plan, inspections, and associated maintenance activities will be treated as PCB Bulk Product Waste, and disposed of in accordance with Toxic Substances Control Act (TSCA) requirements, with the option that metal from which paint has been removed may be managed as scrap metal. In addition, any asbestos waste generated will be handled and disposed of in accordance with ACM regulations, as well as TSCA requirements.

Maintenance of all records and documents will be kept in one centralized location as required by 40 CFR § 761, including, but not limited to, the records required under Subparts J and K. All records will be available for inspection by authorized representatives of the USEPA.



4. Maintenance Record Keeping

GE shall maintain at the facility records relating to the maintenance of ATF piping network system described above. These records will include, but will not be limited to the following:

- PCB M_L marker inspection logs.
- PCB awareness training records.
- Pipe inspection logs.
- 5-Year piping system assessment reports conducted by the third-party engineering firm.
- Updated as-built drawing of the ATF system, revised as pipe changes/replacements occur over time.
- Copies of manifests, bills of lading and/or certificates of destruction for pipe removal/replacement, as applicable.



Attachment A

Record Drawings

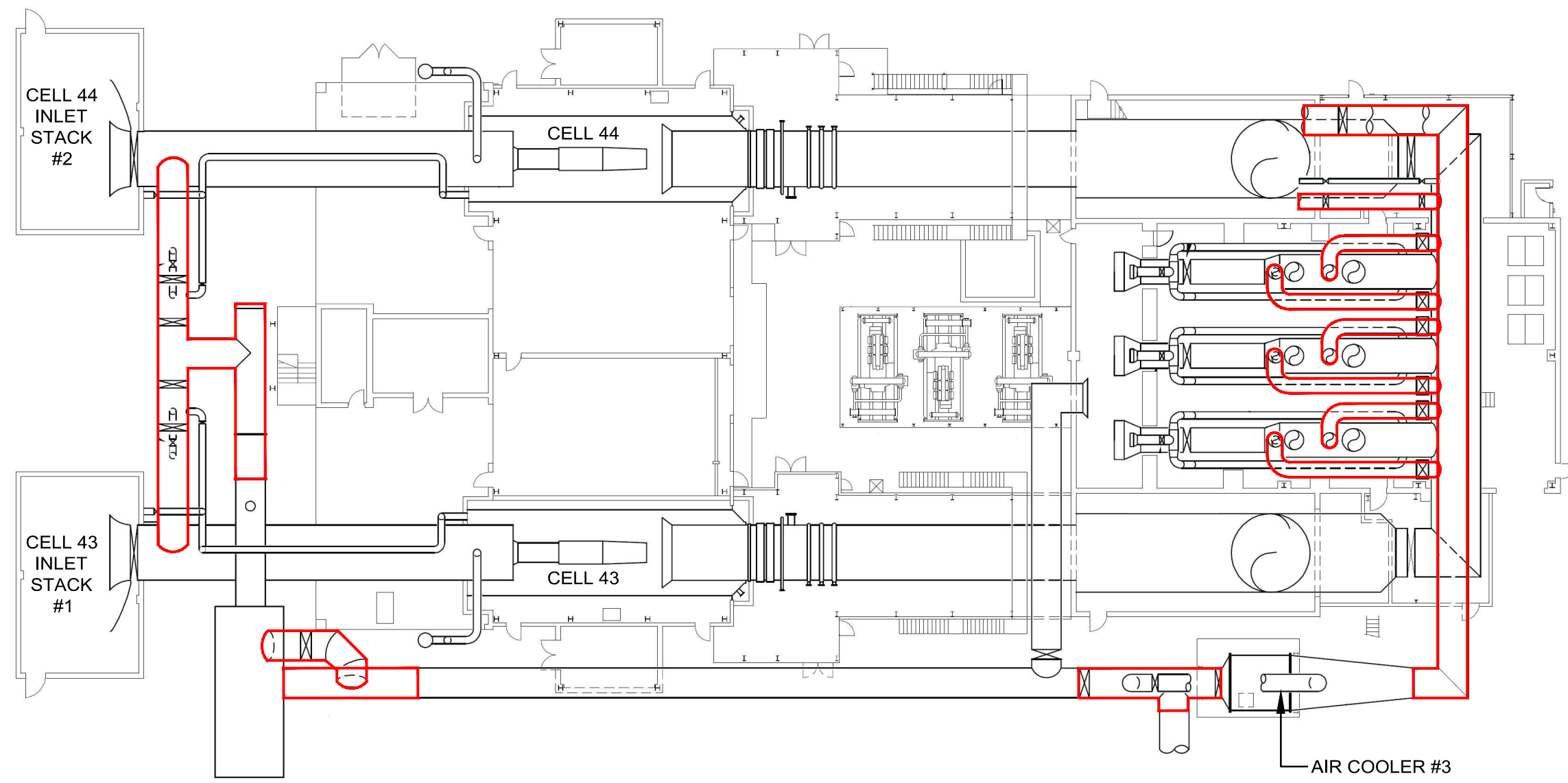

NOT TO SCALE

NOTES:

1. LIMITS OF PAINT ARE POST 2013/14 REMEDIATION EFFORTS.
2. PAINT IS PRESENT ON EXTERIOR OF PIPE ONLY, SURFACE IS UNDER ALUMINUM CLAD INSULATION.

GE-AVIATION CINCINNATI, OHIO O&M RECORD DRAWING	
ATF PIPING NETWORK ELEVATED/UPPER LEVEL	
	FIGURE 1

CITY: SYRACUSE, NY DIV/GROUP: EN/CAD DB: L POSENAUER LD: (Opt) PIC: (Opt) PM: CAVERILL TM: (Opt) LVR: (Opt) ON: "OFF"-REF: V:\EN\CAD\SYRACUSE\ACT\31335\2013\00003\DWG\GO&M\31335G01.dwg LAYOUT: 1 SAVED: 10/10/2013 9:56 AM ACADVER: 18.1S (LMS TECH) PAGESETUP: C-LB-PDF-GMS PLOTSTYLETABLE: PLT\FULL.CTB PLOTTED: 10/10/2013 12:44 PM BY: POSENAUER, USA
 XREFS: IMAGES: 31335X01.plt

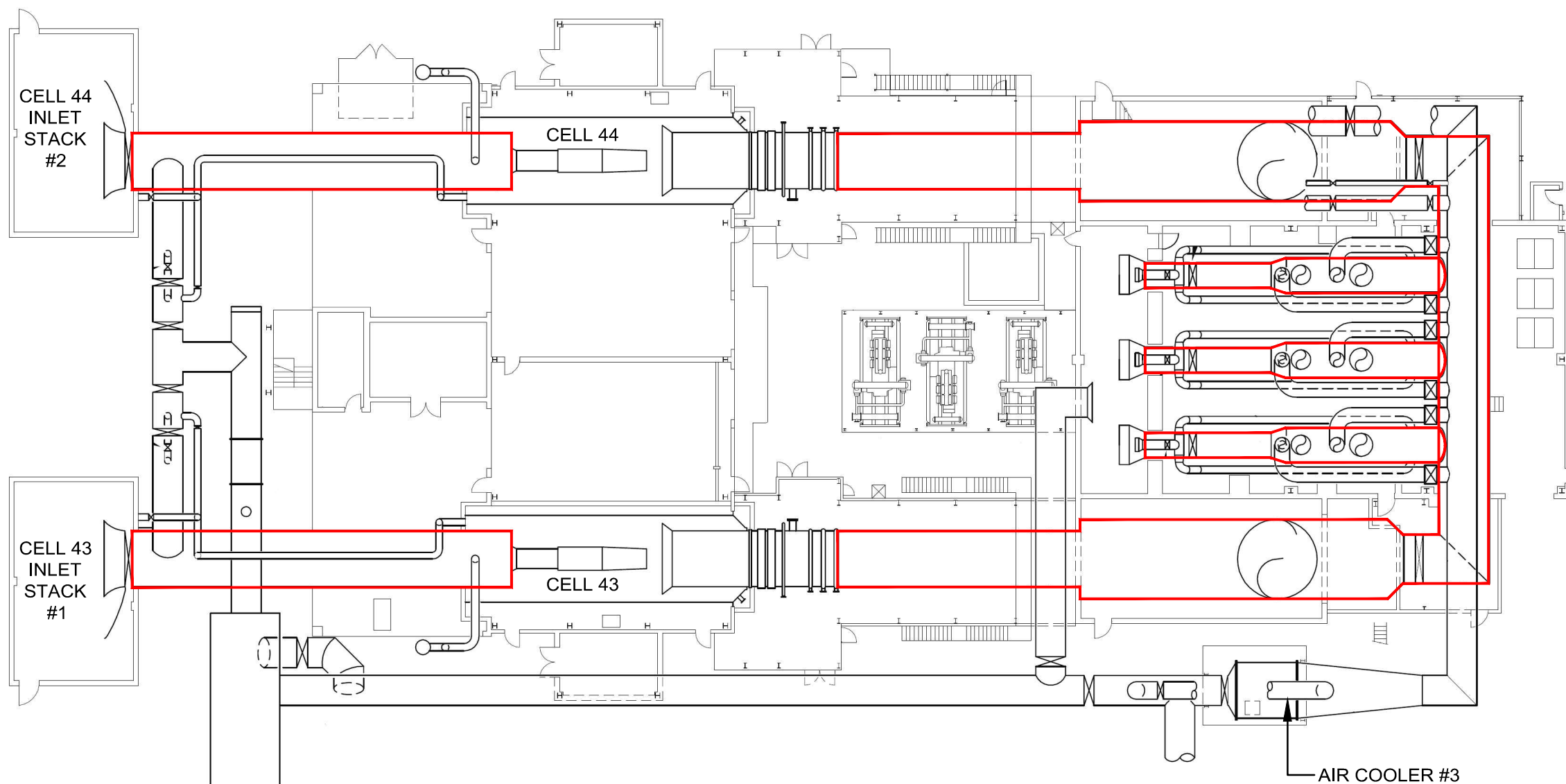

NOT TO SCALE

NOTES:

1. LIMITS OF PAINT ARE POST 2013/14 REMEDIATION EFFORTS.
2. PAINT IS PRESENT ON EXTERIOR OF PIPE ONLY, SURFACE IS UNDER ALUMINUM CLAD INSULATION.

GE-AVIATION CINCINNATI, OHIO O&M RECORD DRAWING	
ATF PIPING NETWORK GROUND/LOOVER LEVEL	
	FIGURE 2

CITY: SYRACUSE, NY DIV/GRP: EN/CAD DB: L POSENAUER LD: (Op) PIC: (Op) PM: CAVERILL TM: (Op) LVR: (Op) ON: "OFF"-REF: V:\EN\CAD\SYRACUSE\ACT\31335\2013\00003\DWG\O&M\31335G02.dwg LAYOUT: 2 SAVED: 10/10/2013 9:56 AM ACADVER: 18.1S (LMS TECH) PAGESETUP: C-LB-PDF-GMS PLOTSTYLETABLE: PLT-FULL.CTB PLOTTED: 10/10/2013 9:56 AM BY: POSENAUER, USA

XREFS: IMAGES: 31335X01.plt